

**MODEL KHT8625
CASING TONGS**

**MAINTENANCE
AND OPERATION MANUAL**

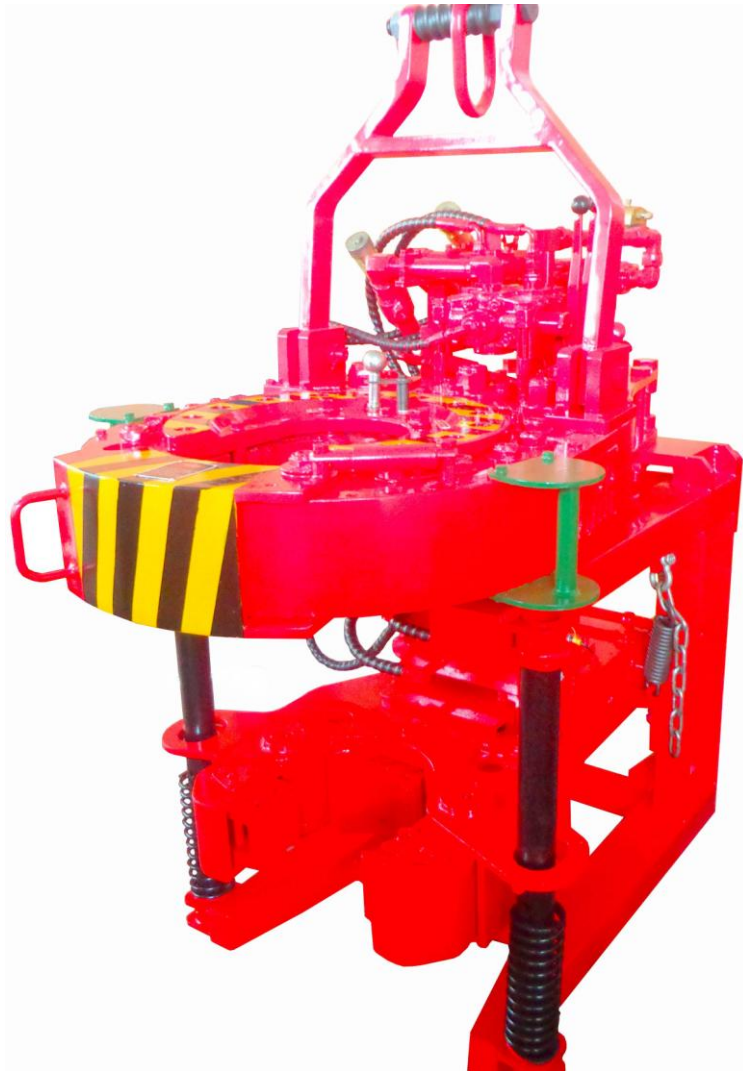

SAFETY CAUTION

1. Operators should read and understand this manual before operation.
2. Operators should wear protective clothing, hard hat and safety boots.
3. Tie the back guy according to the instructions.
4. Make sure to operate at the side of the tong opening.
5. Close the safety door in make-up/break-out operation.
6. Keep hands away from rotating parts.
7. Keep sundries out of the operation range.
8. Cut off the hydraulic source and move the tong off the wellhead during maintenance, changing dies or other parts.
9. Never use the casing tong under over-pressure or over-torque conditions, otherwise the tubing will be damaged and so the planetary gear of the tong will be damaged.
10. Don't dismantle or add parts to the tong.
11. Please adopt the original fitting parts made by

CONTENTS

1.INTRODUCTION.....	1
2.SPECIFICATIONS.....	1
3.INSTALLATION.....	2~7
4. CARE MAINTENANCE.	7~10
5.PROBLEM DIAGNOSIS.....	11
6.STORAGE RECOMMENDATIONS.....	11
7.FIGURES AND DETAILED PARTS TABLES.....	13~53
8.QUICK-WEAR PART.....	52

1. INTRODUCTION

KHT8625 Casing Power Tong is used to make up and break out for casing operation in oil fields. It has greatly reduced the labor of worker, enhanced connection quality of thread and diminished accidents in inappropriate casing operation. The power tong has the following features as well:

- Opening type, convenient and prompt to enter and slide off the working position, with an integral tong head of great strength and rigidity.
- Double swing head jaws, convenient to assemble and disassemble.
- Brake belt assembly, easy to operate and convenient to maintain and replace.
- Open gear supporting structure, improving the strength and rigidity.
- Wholly hydraulic mode and mechanical gear shift.
- High strength steel plate used on the shell, increasing the strength. The jaws are cast with precise technology, artistic and strong.
- With hydraulic torque indicator and also installation interface, convenient to realize the computer management.
- Use safety door hydraulic safety device, of great safety performance.
- Large torque range, can meet the requirement of larger torque use.

2. SPECIFICATIONS

2.1. Jaws available for casing sizes 2 3/8" -8 5/8"

Three kinds of common jaws that we supply: 5 1/2" 、6 5/8" 、8 5/8" ; Others: 2 3/8" 、2 7/8" 、3 1/2" 、4" 、4 1/2" 、5" 、7" 、7 5/8" 、8 5/8" jaws can be equipped according to customer's needs

2.2. Opening size 9" / 228.5mm

2.3. Tong head rotation speed

High gear: 48 rpm

Low gear: 10 rpm

2.4. Rated torque High gear: 5200 ft.lbs/7 kN.m

Low gear: 25000 ft.lbs/34 kN.m

2.5. Rated pressure 2000 PSI/14 MPa

2.6. Work flow 50 GPM/189 L / min

2.7. Overall dimension(L×W×H) 55.1" ×37.5" ×70.8" / 1400×955×1800 mm

2.8. Weight 1100 kg/2400 lb (including Spring lifter assembly)

3. OPERATION

To insure reliable operation of the tong, it is essential that it is suspended properly. Hydraulic hoses must be hooked up correctly, and the following instructions concerning tong start up must be followed:

3.1. Jaw installation (see illustration below):

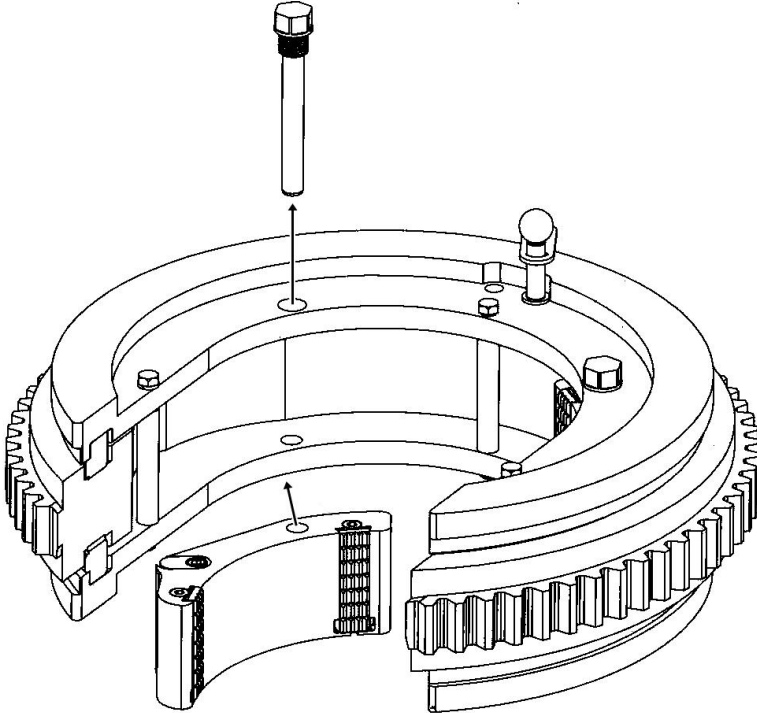

To install the jaws, remove the two jaw pivot bolts from the cage plate. Place one jaw at a time between the upper and lower cage plates with the jaw roller pin facing upward. Align the hole in the jaw with the matching hole in the cage plates, and insert the jaw pivot bolt.

3.2. Tong rig-up

3.2.1. Hang line

The tong should be suspended by 5/8" diameter wire rope, and from a location in the derrick high enough to assure easy handling and maneuvering of the tong. One end of the rope should be placed through the pulley. The other end should be tied off in the derrick to form a dead line through a reaction of about 13kN-18kN to keep balance of the tong. If it can't be tied off in the derrick, it is necessary to use a TEDA double spring hanger assembly. This spring hanger allows the tong to compensate for the downward movement of the casing as the thread made-up.

3.2.2. Hydraulic hoses

When the power unit is not running, or the hydraulic pump is disengaged, the hydraulic hoses may be

installed to the tong. The possibility of error in interchanging the high pressure supply hose and the return hose has been eliminated by using a 1" high pressure hose and a 1-1/4" return hose. These hose couplings are the self-seal type, and care should be taken to insure complete engagement to prevent partial closure of the check valve in the coupling.

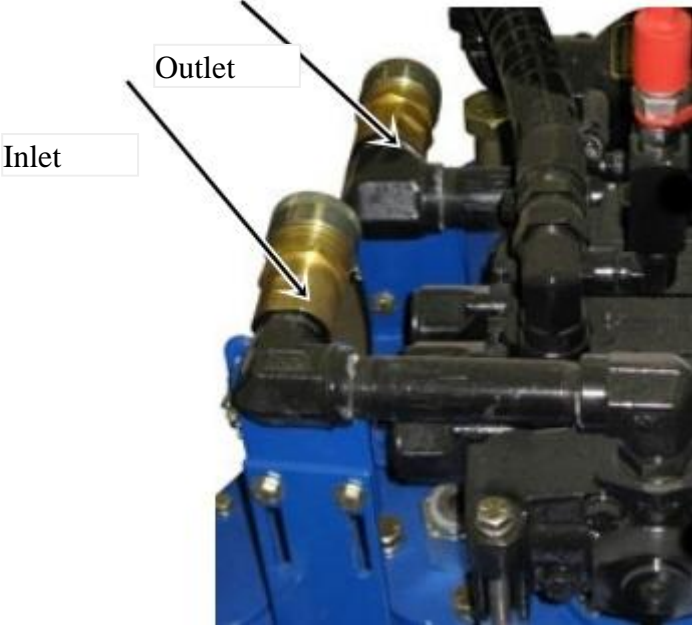

3.2.3. Back-up line

The use of a 5/8" or larger wire rope is recommended for the tong back-up line. It should be securely connected to the load cell at the rear of the tong and tied off to a suitable anchor. To assure accurate operation of the load cell and torque gauge, the back-up line should be connected at a 90 degree angle with the tong, and in the same horizontal plane. (square and level) (see illustration below):

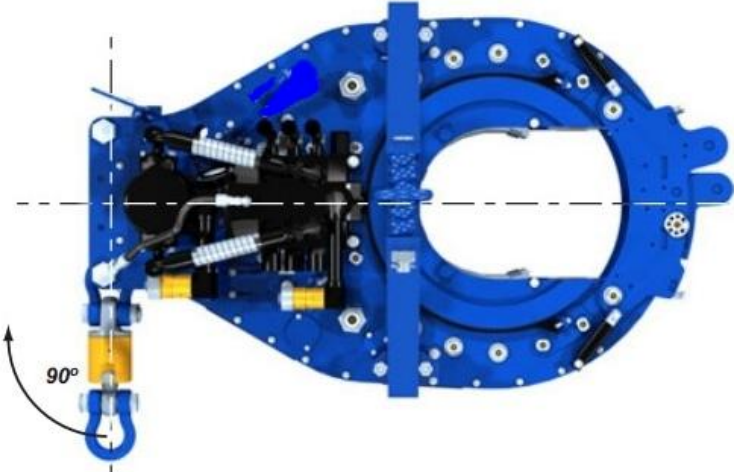

3.3 Tong operation

3.3.1 Start up procedure

Note: be sure the doors are closed and securely latched before power unit is started to insure safety for operation personnel.

Use start up procedures as recommended by the power unit engine operator's manual. Prior to starting engine, an inspection should be made to assure proper lube oil level in the engine and hydraulic oil level in the hydraulic reservoir. Open the by-pass valve on the hydraulic system. Check all pressure and return line hose connections to make sure they are securely installed.

Note: Failure to have these hose connections tight will stop or restrict oil flow and the following failures could occur:

- a. If the pressure supply hose restricts or stops flow, it will result in high pressure on the power unit hydraulic system which will activate the hydraulic governor and speed the engine up to maximum RPM.
- b. If the return line flow is stopped or restricted, it will result in high pressure on the power unit hydraulic system, causing the engine to speed up to maximum RPM and possible failure of the motor seal.

After the hoses are checked, start the engine and allow it to idle until warm. After the power unit engine has been started and hydraulic oil has circulated for approximately 10 minutes, slowly close the by-pass valve which will allow oil to circulate through the hoses and to the tong. (circulating pressure should not exceed 200 PSI.) Place the tong gear shifter in low gear and rotate the tong slowly forward and then reverse with the throttle valve control lever. Once this has been done and the proper size jaws have been installed, the tong is then ready to run pipe.

3.3.2. Direction and speed control

The 4-way valve assembly controls direction, speed of rotation, and torque output. For clockwise rotation, push the valve handle forward, and for reverse rotation, pull the valve handle in the opposite direction. Speed in either direction is proportional to the distance that the valve handle is moved from the center or neutral position (see illustration):



3.3.3. High and low gear

The primary gear box provides for high and low gear operation. For low gear the shifting handle is simply moved upward from neutral position, and for high gear, the shifting handle is moved down from neutral position.

(see illustration)

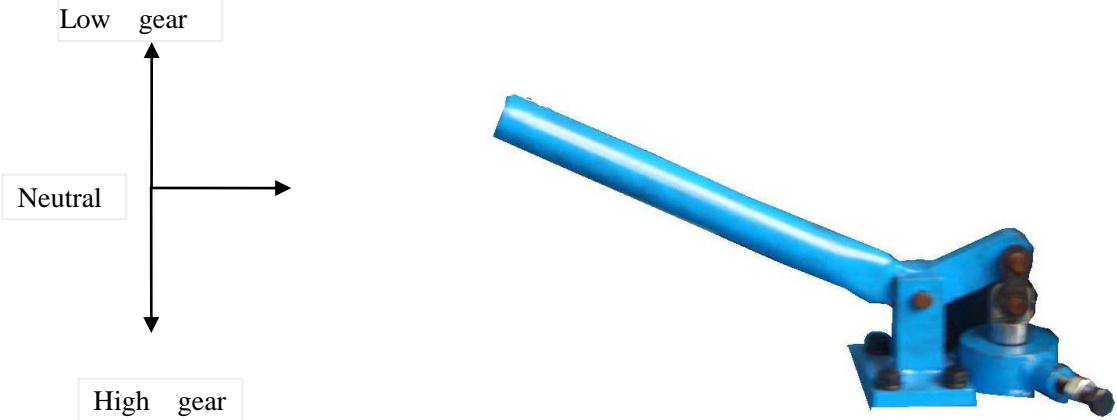

3.3.4. Make up of casing

For proper make-up of a casing joint, the following procedure may be used:

- a. Place tong around casing.
- b. Close and latch door completely.
- C. Place the backing pin in the hole for make-up.

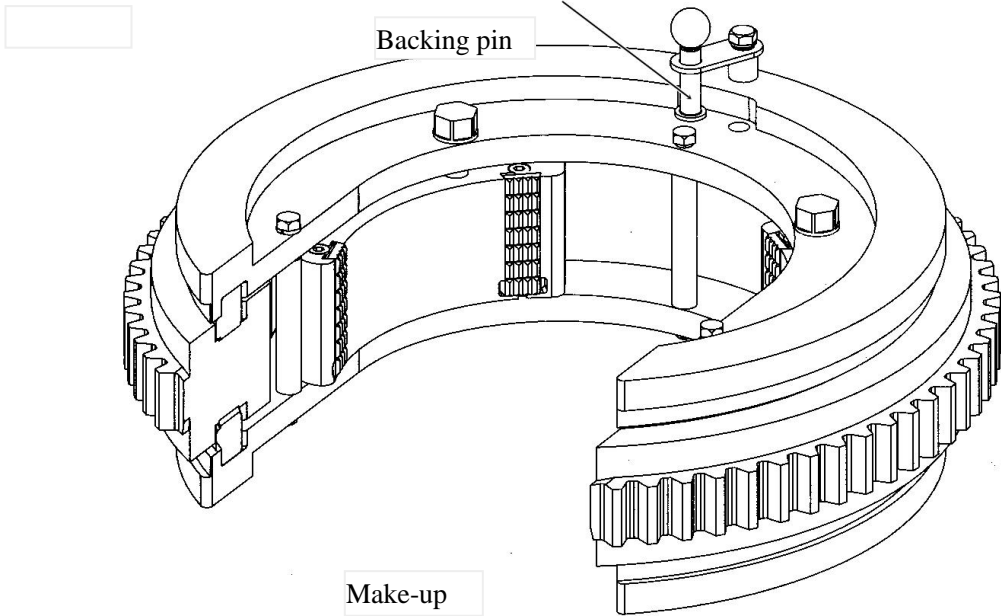

- a. Shift transmission into high gear.
- b. Push the throttle valve handle forward slightly until casing threads begin to make-up.
- c. When casing threads begin to make-up, push the valve handle to full forward until the tong begins to stall.
- d. Release the throttle.
- e. Shift gear box into low gear.
- f. Engage throttle and make-up casing to desired torque.
- g. Reverse tong to disengage jaws and rotate until the table gear aligns with the door opening.
- h. Unlatch the door and remove the tong from pipe.

3.3.5. Break-out of Casing

For proper break-out of a casing joint, the following procedure may be used:

- a. Place tong around casing.
- b. Close and latch door completely.
- c. Place the backing pin in the hole (see illustration below) for break-out

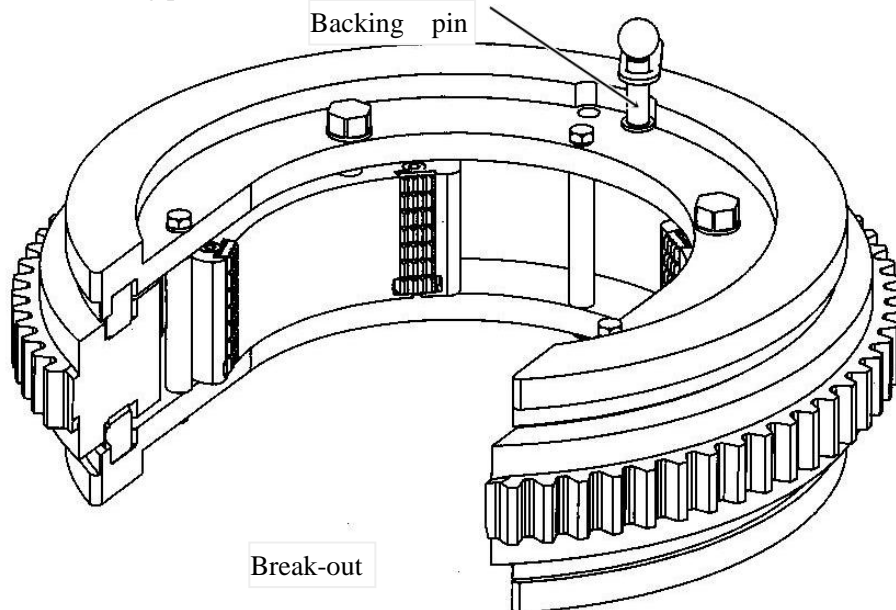

- d. Shift the transmission into low gear.
- e. Pull the throttle valve into full reverse position.
- f. Under most "Break-out" conditions, it is recommended to leave the tong in low gear until the joint is completely unscrewed.
- g. Reverse direction of tong until the table gear aligns with the door opening.
- h. Unlatch the door and remove the tong from pipe.

3.3.6. General comments

a. It is recommended that torque not exceed 8000 ft.lbs. Unless both idler gears are in drive position. This will enhance the life expectancy and dependability of the tong. When operating the tong at high gear, it is recommended to frequently check the tightness of the door and make periodic adjustments to assure a secure door fit.

For safety of rig personnel, make sure the door is securely closed and latched at all times.

b. When make-up integral (shouldered) joints, it is essential to make up the last turn of the threads in low gear. This reduces the tendency of an instant stop or a sudden increase in torque, which induces high stresses to the gear train.

c. When pulling a string, do not employ the “snap break” method of breaking out joints. By definition, the “snap break” method is a procedure used by some operations to break-out connections.

This is accomplished by leaving slack in the “jaw-pipe” engagement, and then quickly pulling the throttle valve control lever allowing the tong to snap into its loaded or high torque conditions. This method, although very affective in breaking out joints, highly stresses the gear train and very frequently causes gear breakage.

This method is also dangerous to operating personnel.

3. 4. Extreme cold weather operation procedures

3.4.1. A hydraulic oil should be selected which is compatible with expected operating climate.

3.4.2. After the power unit has been started, in cold weather climates, the hydraulic oil should be allowed to circulate up to approximately 20 minutes prior to activating the bypass valve allowing fluid to circulate to the tong.

3.4.3 When cleaning tong parts in extreme cold climates, allowance for proper drying of moisture is important prior to lubricating.

4. CARE MAINTENANCE

It is suggested that a regular maintenance program be established, to assure dependable operation of the TEDA Hydraulic power tong. The following recommendations concerning cleaning, lubrication, and adjustments will enhance the life expectancy of the tong and assure safety to operating personnel.

4.1. CLEANING

The tong should be thoroughly cleaned with a good petroleum base cleaning agent, after each job, prior to storage. One month later after usage of the new tong, replace the hydraulic oil to clear the sediment on motor and valve, later, make the change every six months.

4.2. LUBRICATION

A good grade of multipurpose bearing lubricant which is compatible with expected ambient temperatures is recommended along with the following lubrication procedures, at the completion of each job prior to storage

4.2.1 POWER INPUT SHAFT ASSEMBLY BEARINGS

Unscrew the plug screws on the bearing cover, grease should be applied to these bearings through the grease fittings in the bearing cap located at the bottom face of the tong.

4.2.2 BIG IDLER GEAR ASSEMBLY, SMALL IDLER GEAR ASSEMBLY, PINION ASSEMBLY

Grease should be applied to these bearings through the grease fittings in the end of the shaft located at the top face of the tong. (see illustration below):

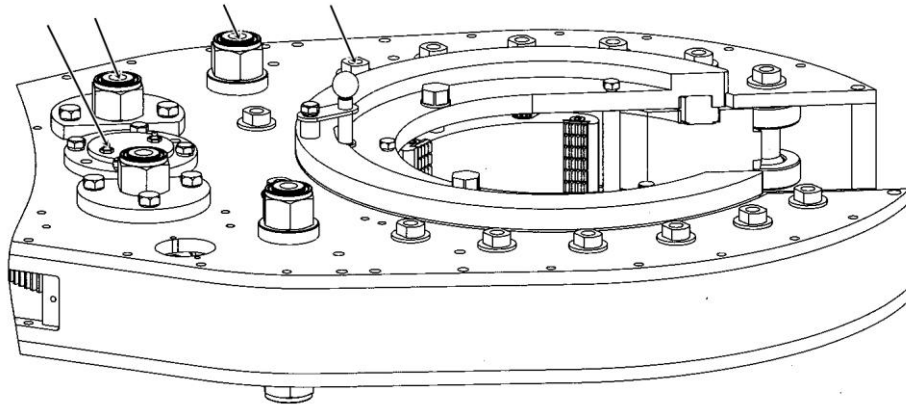

4.2.3 Grease should be applied to these centralizing roller bearings through the grease fittings at the end of the shafts located at the top and bottom face of the tong. (see illustration above):

4.2.4 Apply grease to the reversing shaft through the shaft seat mouth.

4.3. ADJUSTMENTS

BRAKE BAND ADJUSTMENT (see illustration):

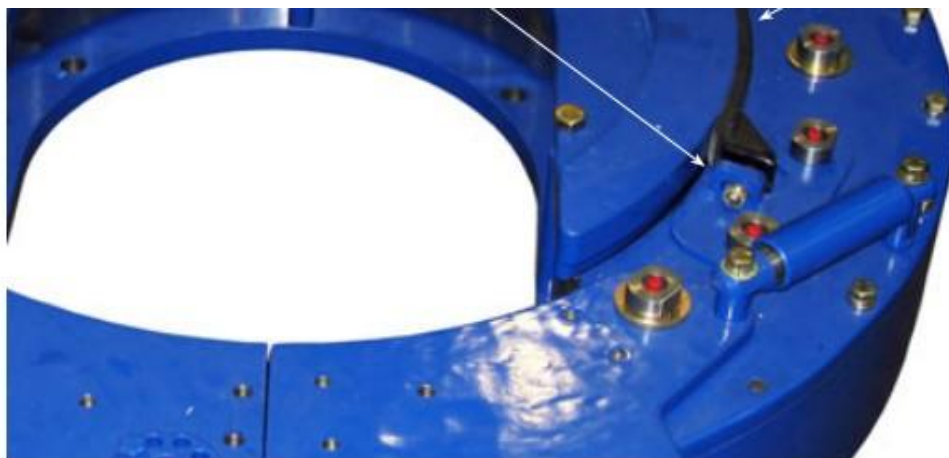

As the tong is used, it becomes necessary at times to adjust the brake bands to provide a smoother and more efficient jaw cam action. If the cage plate turns with the rotary gear, the jaws will not cam properly and therefore, will not bite on the tubing or casing. By tightening the brake band against the cage plates, enough frictional resistance occurs to allow jaws to cam properly and grip the casing. To adjust the brake band, simply turn the adjustment bolt clockwise to tighten and counterclockwise to loosen.

4.4. PERIODIC CHECK LIST

4.4.1. SHIFTING SHAFT

The shifting Yoke is secured to the shifting shaft by one hex jam nut $3/8'' \times 1 3/4''$ and one nut on the bottom of the yoke. These nuts should be checked after each job. This can be accomplished by removing the clutch inspection plate and insuring a snug fit prior to lubrication.

4.4.2. TORQUE GAUGE ASSEMBLY

Periodic calibration of the torque gauge is recommended to assure accurate torque readings. When having the torque gauge serviced and calibrated, it is important to note that the arm length on the TEDA 20" tong is 52" inches.

4.5. OVERHAUL PROCEDURES

Should the need arise to overhaul any portion of the tong, certain disassembly procedures must be followed. Access to the gear train is possible by removal of the top plate of the tong.

NOTE: All maintenance and overhaul should be accomplished from the top. Therefore, the bottom plate of the tong should never be removed from the gear case housing.

4.5.1 The first step in disassembly of the top plate for overhaul is to remove the motor-valve assembly. This is accomplished by removing the four $1/2'' \times 3 1/4''$ socket head cap screws, which secure the motor to the motor mount, and removing the four $1/2'' \times 3 1/4''$ hex head screws, which secures the valve to the valve mount. The motor-valve assembly may then be lifted off.

4.5.2. Disconnect & remove the linkage between the shifting handle and the shifting shaft.

4.5.3. Back-off the shifting detent bolt ($7/16'' \times 1 1/4''$). This relieves compression on the spring and allows the ball to disengage from the groove in the shifting shaft. Remove the shifting detent bolt and, using pencil magnets, extract the ball and spring before the shifting shaft is removed; this prevents loss of the ball inside the tong.

4.5.4. Remove the doors. This is accomplished as follows:

4.5.4.1 Remove the two door stop assemblies by removing the screw 1 per assembly.

4.5.4.2 Remove the top lock nuts from the door roller shaft.

4.5.4.3 Remove the grease fittings from the end of the door roller shafts and drive the shafts out. The shafts should be very carefully driven out with a soft alloy material (e.g., brass rod, etc.) to eliminate the possibility of damage to the shafts or door. This then allows the doors to be removed.

Note: When removing the doors make careful note of the bearing shims which align the doors. At reassemble of the doors after overhaul, it will still be necessary to reassemble door bearing shims in the same sequence to assure desired door alignment.

4.5.5. The next step is to loosen the top and bottom brake band. This is accomplished by backing off the brake band adjustment bolts until the nut is flush with the end of the bolt.

4.5.6. With the brake bands loosened, the next step is to remove the top and bottom cage plate. This is accomplished by removing the three cage plate support bolts. With these three bolts removed, the top cage plate can be lifted off.

Note: Care should be taken in removing the cage plate bolts as they are the only means of support for the bottom cage plate, after the brake band is loosened. To prevent damage to the bottom cage plate or personal injury to the mechanic, it is recommended that the bottom cage plate be braced while the mechanic removes the three cage plate bolts.

4.5.7. Remove the lock nut and washer from the big idler gear assembly, small idler gear assembly, centralizing roller assembly on the face plate. Remove the $3/8" \times 1-1/2"$ long hex head bolts from the case body assembly.

4.5.8. With all the above steps taken, the top tongue plate can be lifted off providing access to the inside of the gear case.

5. PROBLEM DIAGNOSIS

Trouble	Causes	Remedy
The head doesn't Turn	<ol style="list-style-type: none"> 1. No pressure from hydraulic station. 2. Damage of the hydraulic reversing valve. 3. Gear changing system fails. 	<ol style="list-style-type: none"> 1. Check the station. Add pressure. 2. Replace the valve. 3. Repair
Speed is not enough	<ol style="list-style-type: none"> 1. Low pressure or low flow from the power station. 2. Bad leakage loss from oil motor or hand-reversing valve. 	<ol style="list-style-type: none"> 1. Check the station pressure. 2. Replace the motor or hand-reversing valve.
Head slide	<ol style="list-style-type: none"> 1. Disagreement of the sizes of the jaws and casing. 2. Tongs not be leveled. 3. Dies worn out. 4. Die notch filled with oil dirt. 5. Brake band too loose or worn out. 6. Jaw roller failure to turn. 	<ol style="list-style-type: none"> 1. Change the jaws. 2. Level the tongs. 3. Change the dies. 4. Get rid of it with a wire brush. 5. Adjust or change the band. 6. Check the roller or oil and repair the pin shaft.
Torque valve less than rated	<ol style="list-style-type: none"> 1. Low pressure from the hydraulic power station or its insufficient oil discharge. 2. Function failure of the hydraulic motor or of the reversing valve. 3. Insufficient oil in the torque cylinder or the sealing ring worn out. 4. Torque gauge failure. 	<ol style="list-style-type: none"> 1. Deal with it according to the instruction of hydraulic power station. 2. Repair or change it. 3. Fill in oil or change the ring. 4. Repair or change the torque gauge.
Motor is running but the tong head keeps still or moves slowly, or will stop even loaded light	<ol style="list-style-type: none"> 1. Gear changing device fails 2. Much leakage loss from the hydraulic motor or the hand-reversing valve. 3. Gear of gearbox damaged or seriously worn out. 	<ol style="list-style-type: none"> 1. Repair or change. 2. Repair or change the motor and the valve. 3. Check or repair the gearbox .

6. STORAGE RECOMMENDATIONS

6.1. When storing the tong, an effort should be made to locate the unit in a clean, dry, ventilated area.

6.2. The tong, while in storage, should be well lubricated.

6.3. Spare moving parts (gears, shafts, etc.), if required to remain in storage for a long period of time, tong should be coated with a good corrosion inhibitor, and should be stored in a good dry environment.

6.4. All O' rings, seals, packings, gaskets, etc., should be stored in a good moisture proof, air tight container.

6.5. All bearings (cam followers, roller bearing, etc.) should be well lubricated and stored in a dust free box or container, protected from moisture.

7. Figures and detail list of parts

7.0 KHT8625 General assembly (Fig 1, Table 1)

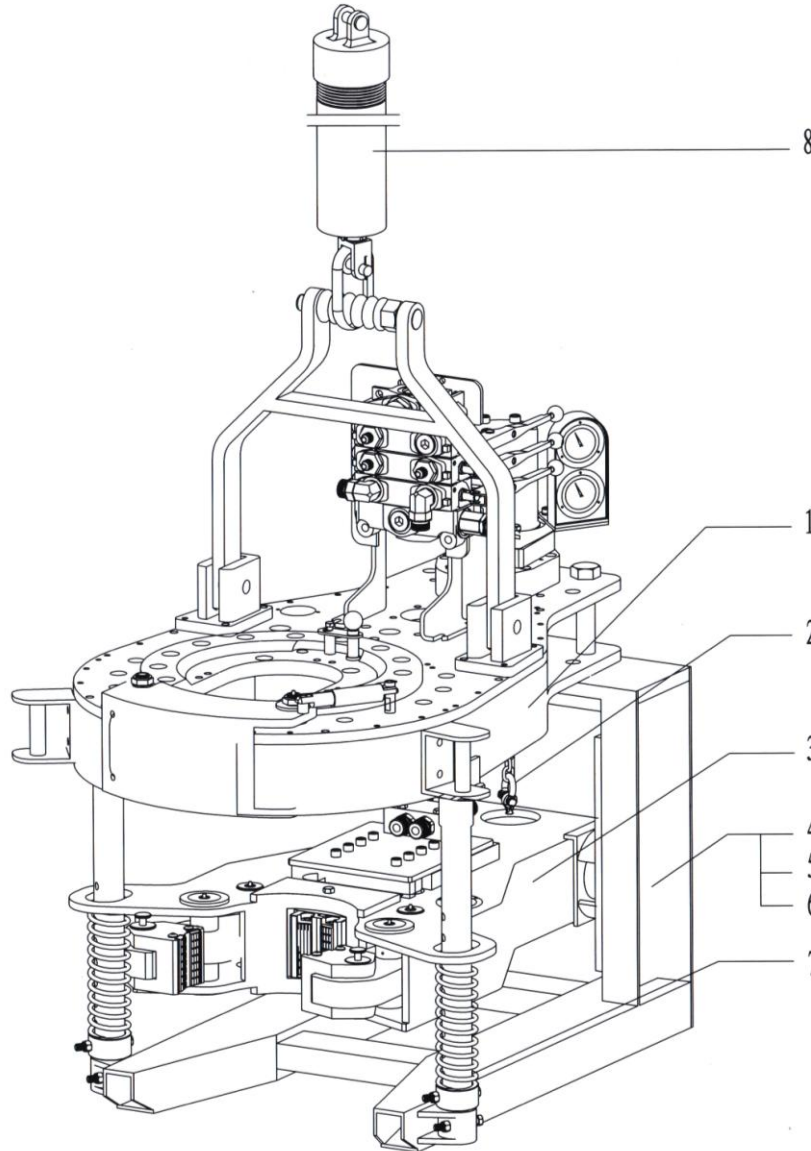

Fig. 1

Table 1 Detailed table for General assembly

No.	P/N	Drawing No.	Names and specifications of parts	QTY
1	KHT8625-01	KHT8625.1	Master tong	1
2	KHT8625-02	KHT8625.3	Suspension chain assembly	2
3	KHT8625-03	KHT8625.2	Back tong	1
4	KHT8625-04	KHT8625.4	Rear support	1
5	KHT8625-05	KHT9625.2-11	Fixing bolt	1
6	KHT8625-06		Stop nut 1"	
7	KHT8625-07	KHT5500.5	Front guide assembly	2
8	KHT8625-08	TQ340/35YA.1.16	Hydraulic spring tube assembly	1

7.1 KHT8625Master tong assembly(Fig.2, Fig.3, Table.2)

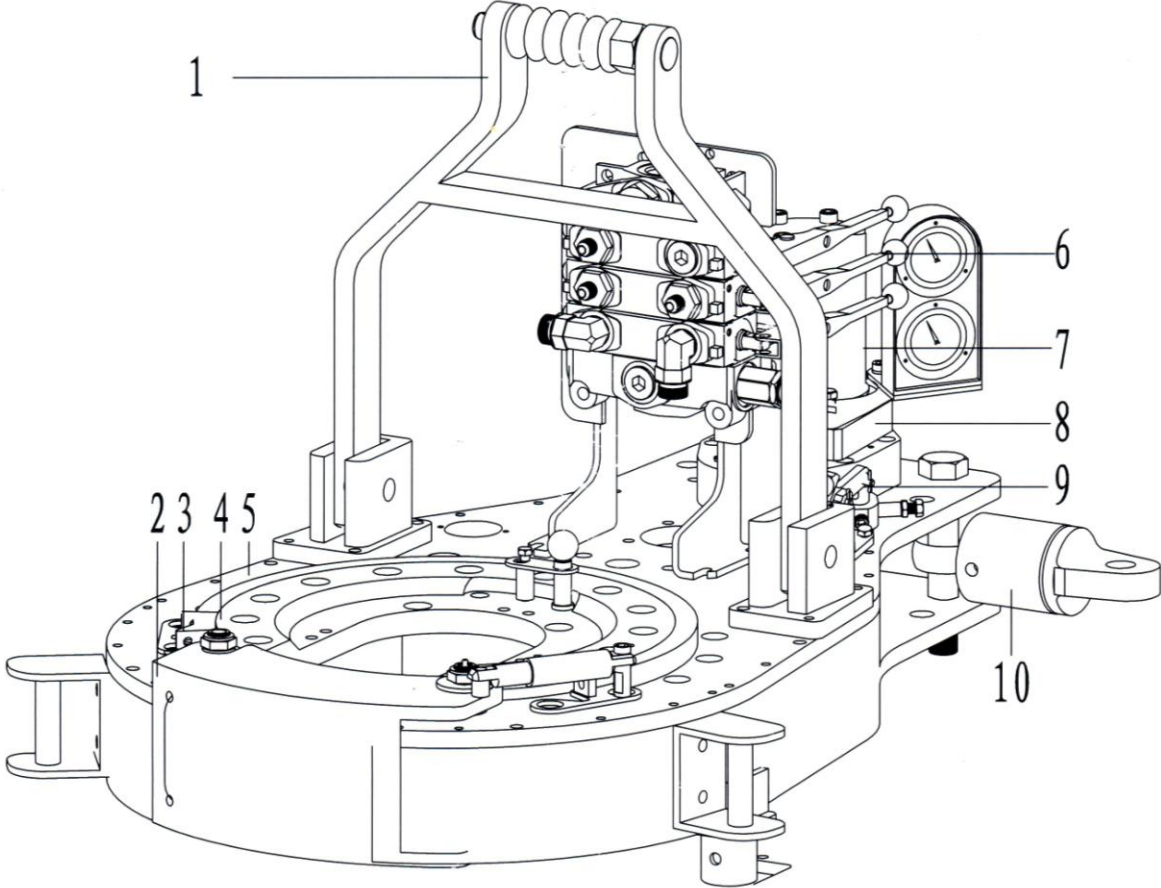

Fig. 2

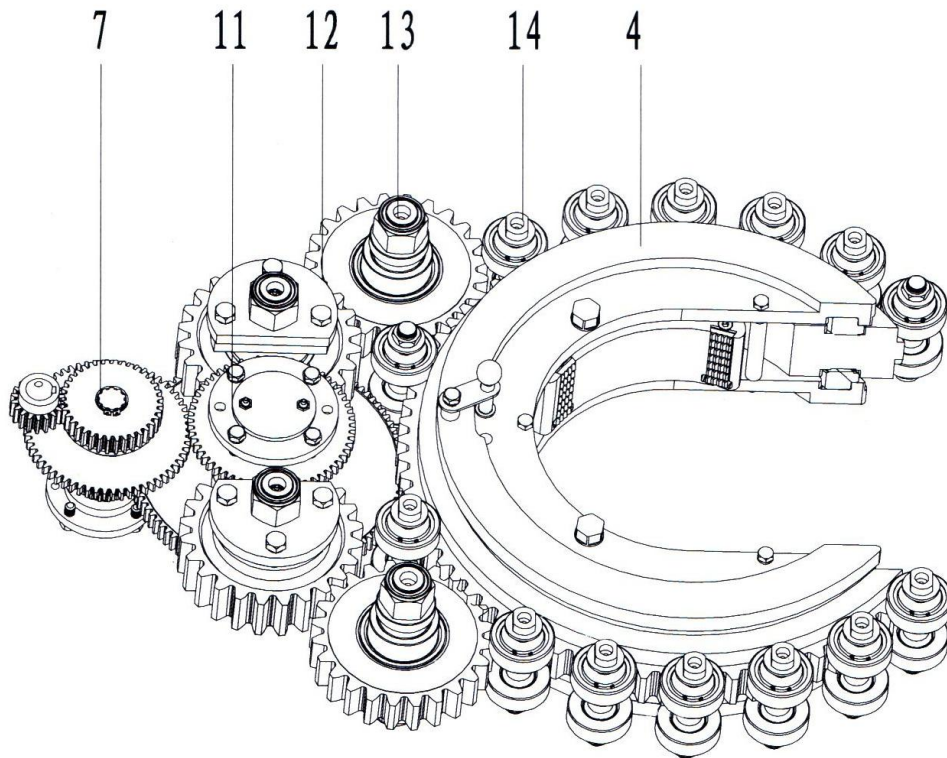

Fig. 3

Table. 2 Detailed table for KHT8625Master tong assembly

No.	P/N	Drawing No.	Names and specifications of parts	QTY
1	KHT8625-22	KHT8625.1.13	Suspension rod assembly	1
2	KHT8625-23	KHT8625.1.10	Safety door assembly	1
3	KHT8625-24	KHT8625.1.12	Brake band assembly	2
4	KHT8625-25	KHT8625.1.1	Tong head assembly	1
5	KHT8625-26	KHT8625.1.2	Shell	1
6	KHT8625-27	KHT8625.1.8	Hydraulic valve and line	1
7	KHT8625-31	KHT8625.1.6	Power input shaft assembly	1
8	KHT8625-29	KHT8625.1.7	Small cabinet assembly	1
9	KHT8625-28	KHT8625.1.11	Shifter assembly	1
10	KHT8625-30	KHT8625.1.14	Torque test assembly	1
11	KHT8625-32	KHT8625.1.5	Triple gear assembly	1
12	KHT8625-33	KHT8625.1.4	Big idler gear assembly	2
13	KHT8625-34	KHT8625.1.3	Small idler gear assembly	2
14	KHT8625-35	TQ508/70Y.2.1	Centralizing assembly(1)	1

7.1.1 Tong head assembly(Fig.4, Table.3)

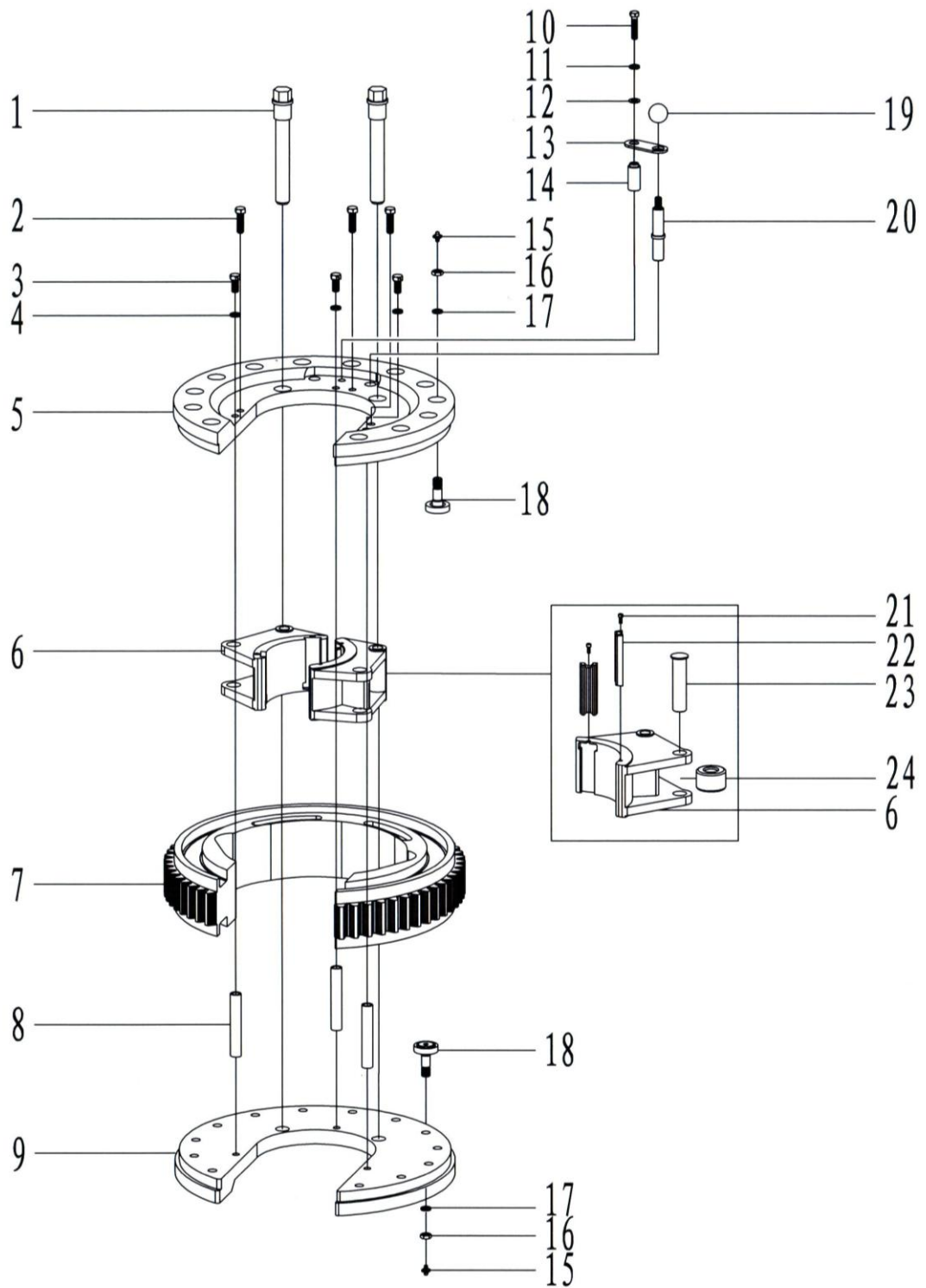

Fig. 4

Table.3 Detailed table for tong head assembly

No.	P/N	Drawing No.	Names and specifications of parts	QTY
1	KHT8625-61	KHT8625.1.1-6	Jaw set bolt	2
2	KHT8625-62		Hexagon bolt 1/2" -13UNC×3/4"	3
3	KHT8625-63		Hexagon head bolt with hole 1/2" ×8"	3
4	KHT8625-64		Spring washer 1/2"	3
5	KHT8625-65	KHT8625.1.1-1	Upper jaw set bracket	1
6	KHT8625-94	KHT8625.1.1.1(1)	Jaw set (1) 8 5/8"	
	KHT8625-66	KHT8625.1.1.1(2)	Jaw set (2) 7 5/8"	2
	KHT8625-67	KHT8625.1.1.1(3)	Jaw set (3) 7"	2
	KHT8625-68	KHT8625.1.1.1(4)	Jaw set (4) 6 5/8"	2
	KHT8625-69	KHT8625.1.1.1(5)	Jaw set (5) 5 1/2"	2
	KHT8625-70	KHT8625.1.1.1(6)	Jaw set (6) 5"	2
	KHT8625-71	KHT8625.1.1.1(7)	Jaw set (7) 4 1/2"	2
	KHT8625-72	KHT8625.1.1.1(8)	Jaw set (8) 4"	2
	KHT8625-73	KHT8625.1.1.1(9)	Jaw set (9) 3 1/2"	2
	KHT8625-74	KHT8625.1.1.1(10)	Jaw set (10) 2 7/8"	2
	KHT8625-75	KHT8625.1.1.1(11)	Jaw set (11) 2 3/8"	2
7	KHT8625-76	KHT8625.1.1-2	Open gear	1
8	KHT8625-77	KHT8625.1.1-4	Shaft sleeve (1)	3
9	KHT8625-78	KHT8625.1.1-5	Lower jaw set bracket	1
10	KHT8625-79		Hexagon bolt 3/8" ×2 1/2"	1
11	KHT8625-80		Spring washer 3/8"	1
12	KHT8625-81	GB/T95	Flat washer 10	1
13	KHT8625-82	KHT8625.1.1-8	Connecting plate	1
14	KHT8625-83	KHT8625.1.1-9	Shaft sleeve (2)	1
15	KHT8625-84	GB/T1152	Grease cup M6×1	50
16	KHT8625-85		Hexagon thin nut 5/8" -18UNF	50
17	KHT8625-86		Spring washer 5/8"	50
18	KHT8625-87	KJD9625.2.1	Centering roller	50
19	KHT8625-88	KJD9625.1.1-1	Handle ball	1
20	KHT8625-89	KHT8625.1.1-7	Reverse shaft	1
21	KHT8625-90		Hexagon socket countersunk head screw 5/16" UNC×1/2"	4
22	KHT8625-91	KHT9625.1.1.1-2(2)	Die 2(1/2)	4
23	KHT8625-92	KHT8625.1.1.1-3	Roller shaft	2
24	KHT8625-93	KHT8625.1.1.1-2	Roller	2

7.1.2 Case body assembly(Fig.5, Table.4)

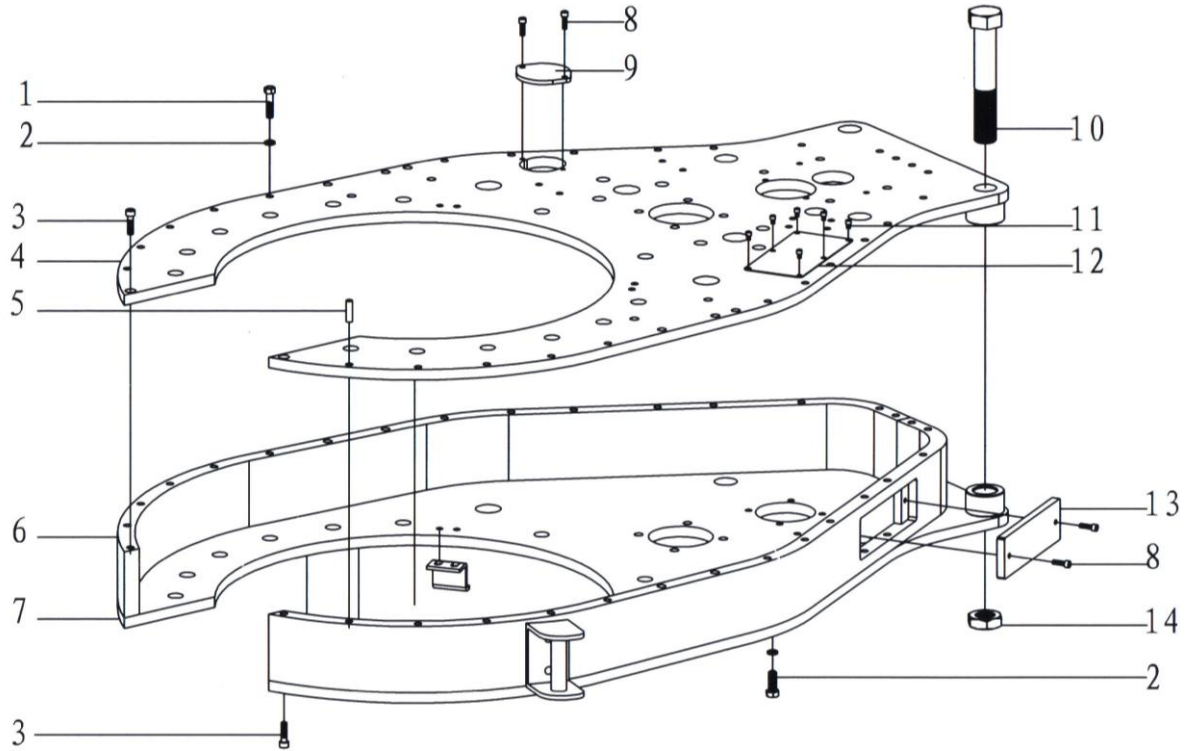

Fig. 5

Table. 4 Detailed table for Case body assembly

No.	P/N	Drawing No.	Names and specifications of parts	QTY
1	KHT8625-114		Hex head bolt 3/8" UNC×1 1/2"	44
2	KHT8625-115		Spring washer 3/8"	44
3	KHT8625-116		Hexagon socket cap screw 3/8" ×1 1/4"	4
4	KHT8625-117	KHT8625. 1. 2-1	Face plate	1
5	KHT8625-118		Cylinder pin 3/8" ×1 1/4"	16
6	KHT8625-119	KHT8625. 1. 2-2	Side plate	2
7	KHT8625-120	KHT8625. 1. 2-3	Base plate	1
8	KHT8625-126		Hexagon socket cap screw 1/4UNC×3/4"	4
9	KHT8625-121	KJD9625. 16	Locating seat	1
10	KHT8625-122	KHT8625. 1. 2-5	Tail guy bolt	2
11	KHT8625-123		Hexagon socket cap screw 1/4" ×5/16"	6
12	KHT8625-124	KHT8625. 1. 2-10	Nameplate	1
13	KHT8625-125	KHT8625. 1. 2-7	Baffle	1
14	KHT8625-127		Lock nut 1 1/4" UNC	2

7.1.3 Small idler gear assembly(Fig.6, Fig.7, Table.5)

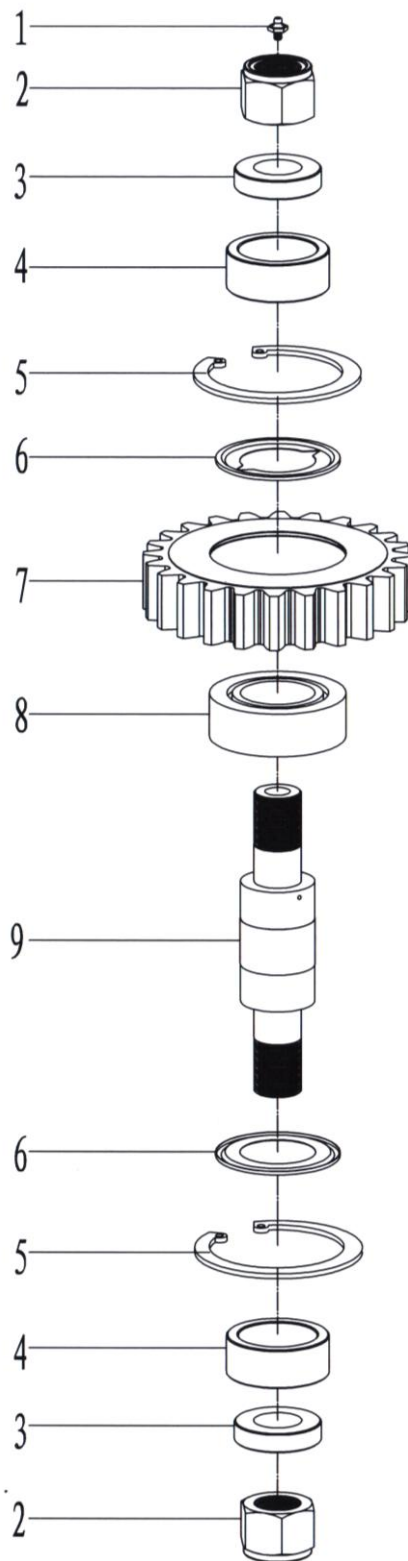

Fig. 6

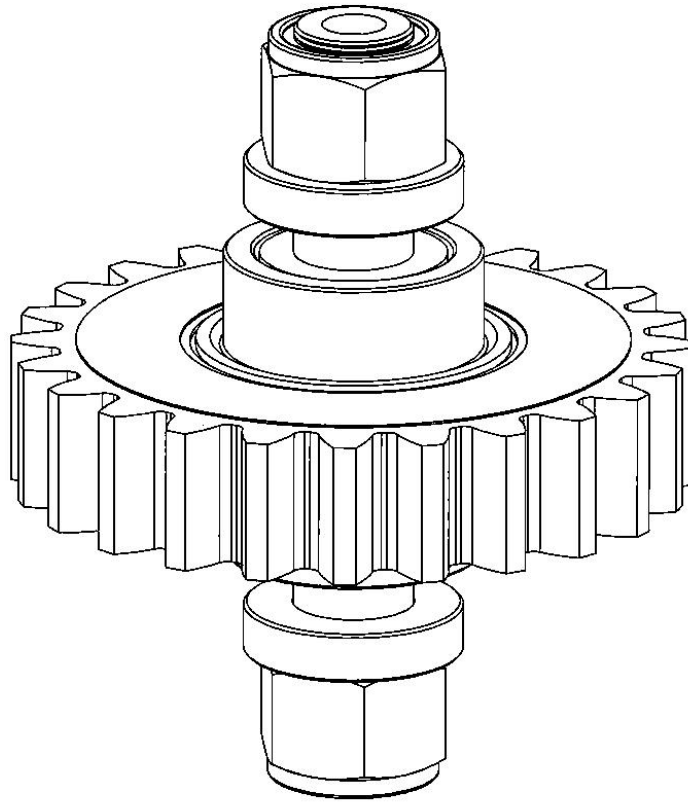

Fig. 7

Table. 5 Detailed table for Small idler gear assembly

No.	P/N	Drawing No.	Names and specifications of parts	QTY
1	KHT8625-150		Grease cup NPT1/8	2
2	KHT8625-151	TQ508/70Y.3.1	Lock nut 1 1/2"-12UNF	4
3	KHT8625-152	KHT13625.1.3-1	Washer	4
4	KHT8625-153	KHT8625.1.3-2	Lining ring	4
5	KHT8625-154		Circlip for hole 110	4
6	KHT8625-155	TQ508/70Y.3-4	Water-proof guard(1)	4
7	KHT8625-156	KHT13625.1.3-4	Small idler gear	2
8	KHT8625-157		Cylindrical roller bearing INA3212	2
9	KHT8625-158	KHT8625.1.3-1	Small idler gear shaft	2

7.1.4 Big idler gear assembly(Fig.8, Fig.9, Table.6)

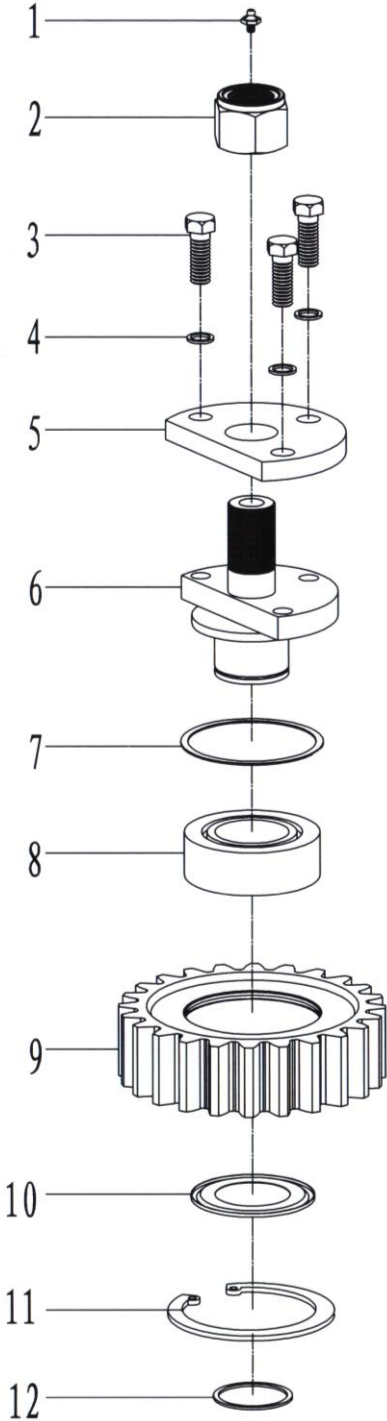

Fig. 8

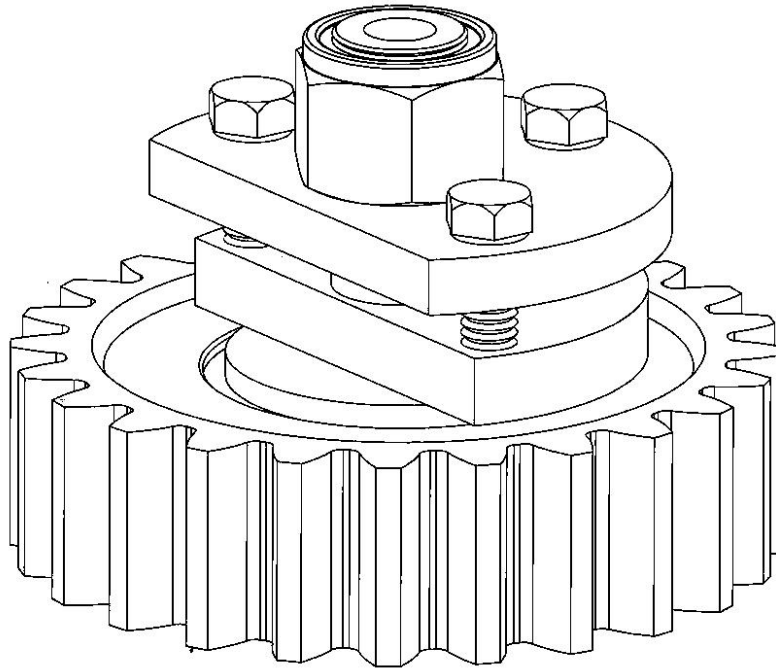

Fig. 9

Table. 6 Detailed table for Big idler gear assembly

No.	P/N	Drawing No.	Names and specifications of parts	QTY
1	KHT8625-150		Grease cup NPT1/8	2
2	KHT8625-151	TQ508/70Y.3.1	Lock nut 1 1/2	2
3	KHT8625-182		Hex head bolt 5/8"×2"	6
4	KHT8625-86		Spring washer 5/8"	6
5	KHT8625-184	KHT13625.1.4-1	Idler gear cover	2
6	KHT8625-185	KHT8625.1.4-1	Big idler gear shaft	2
7	KHT8625-154	TQ508/70Y.3-5	Retainer ring	4
8	KHT8625-157		Cylindrical roller bearing INA3212	2
9	KHT8625-156	KHT13625.1.3-4	Big idler gear	2
10	KHT8625-155	TQ508/70Y.3-4	Water-proof guard(1)	2
11	KHT8625-190	GB/T894.2	Retaining rings for shafts 60	2

7.1.5 Pinion assembly(Fig.10, Fig.11, Table.7)

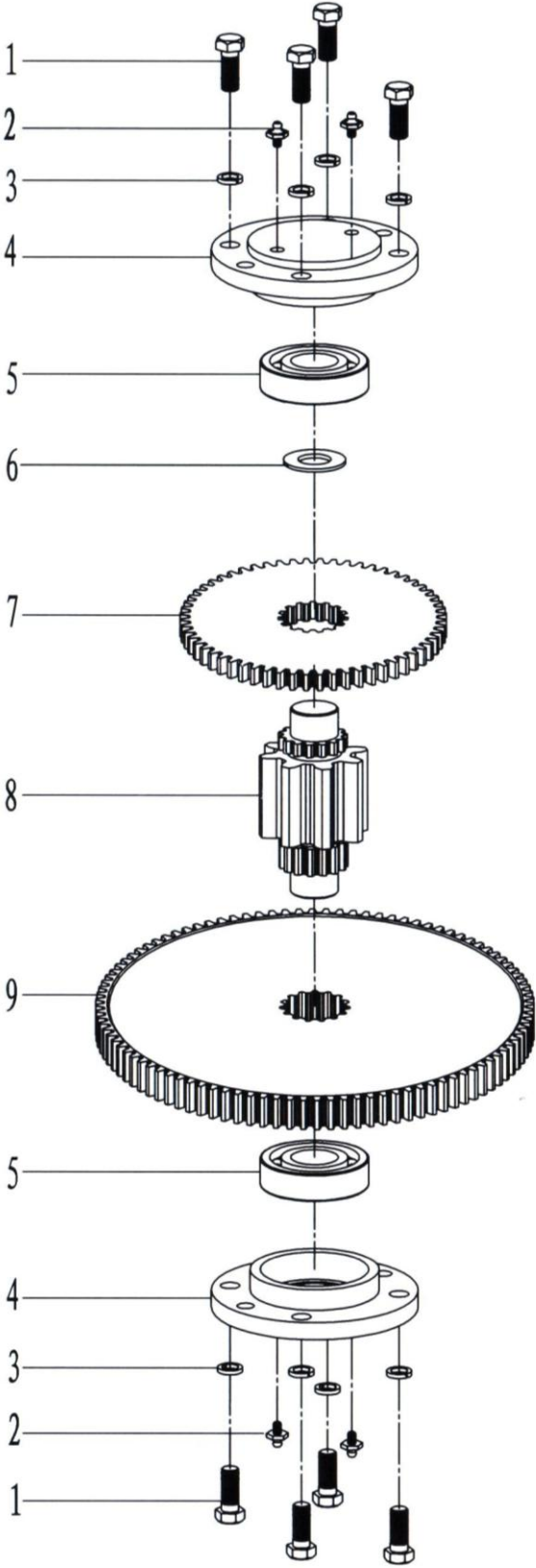

Fig. 10

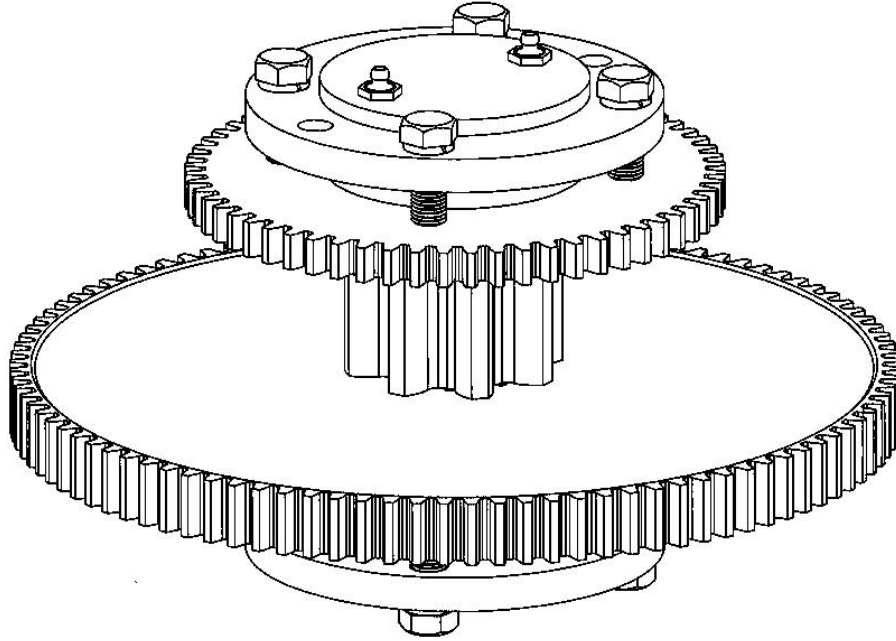

Fig. 11

Table. 7 Detailed table for Pinion assembly

No.	P/N	Drawing No.	Names and specifications of parts	QTY
1	KHT8625-210		Hex head bolt 1/2"UNC×1 1/4"	8
2	KHT8625-150		Grease cup NPT1/8"	4
3	KHT8625-64		Spring washer1/2"	8
4	KHT8625-213	KHT8625.1.5-1	Bearing cap	2
5	KHT8625-214	GB/T278	Pinion bearing 60307	2
6	KHT8625-215	KHT8625.1.5-5	Washer	1
7	KHT8625-216	KHT8625.1.5-2	Small gear	1
8	KHT8625-217	KHT8625.1.5-3	Pinion gear shaft	1
9	KHT8625-218	KHT8625.1.5-4	Big gear	1

7.1.6 Power input shaft assembly(Fig.12, Fig.13, Table.8)

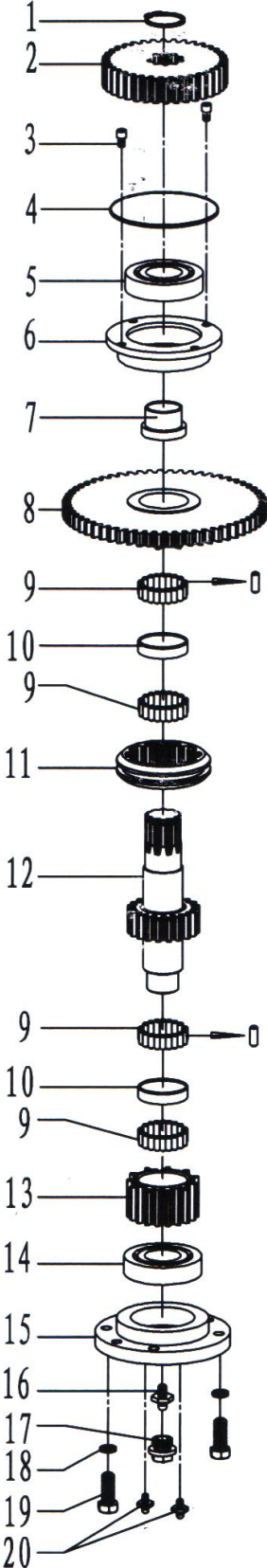

Fig. 12

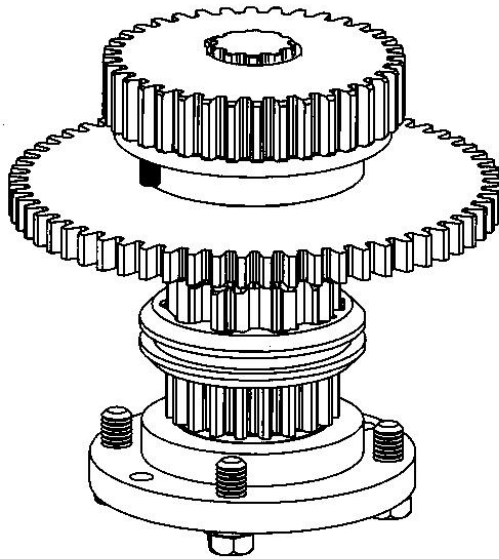

Fig. 13

Table. 8 Detailed table for Power input shaft assembly.

No.	P/N	Drawing No.	Names and specifications of parts	QTY
1	KHT8625-230	GB/T894.1	Circlip for shaft 28	1
2	KHT8625-231	KHT8625.1.6-4B	Drive gear	1
3	KHT8625-232		Hexagon socket cap screw #10×3/4"	2
4	KHT8625-233	GB/T305	Stop ring 72/78.2	1
5	KHT8625-234	GB/T277	Ball bearing with snap ring 6306	1
6	KHT8625-235	KHT8625.1.6-6	Bearing seat	1
7	KHT8625-236	KHT8625.1.6-3	Bushing	1
8	KHT8625-237	KHT8625.1.6-7	Duplex gear	1
9	KHT8625-238		Needle 1/8"×5/8"	124
10	KHT8625-249	KHT8625.1.6-13	Spacer ring	2
11	KHT8625-239	KHT8625.1.6-8	Inner gear sleeve	1
12	KHT8625-240	KHT8625.1.6-2	Main shaft	1
13	KHT8625-241	KHT8625.1.6-9	Clutch small gear	1
14	KHT8625-242		Cylindrical roller bearing 3205	1
15	KHT8625-243	KHT8625.1.6-11	Lower bearing support	1
16	KHT8625-150		Grease cup NPT1/8	1
17	KHT8625-245	KHT13625.1.6-12	Plug screw	1
18	KHT8625-80		Spring washer 3/8"	4
19	KHT8625-116		Hex bolt 3/8"UNC×1 1/4"	4
20	KHT8625-248		Grease cup NPT1/8×90°	2

7.1.7 Case body assembly(Fig.14, Table.9)

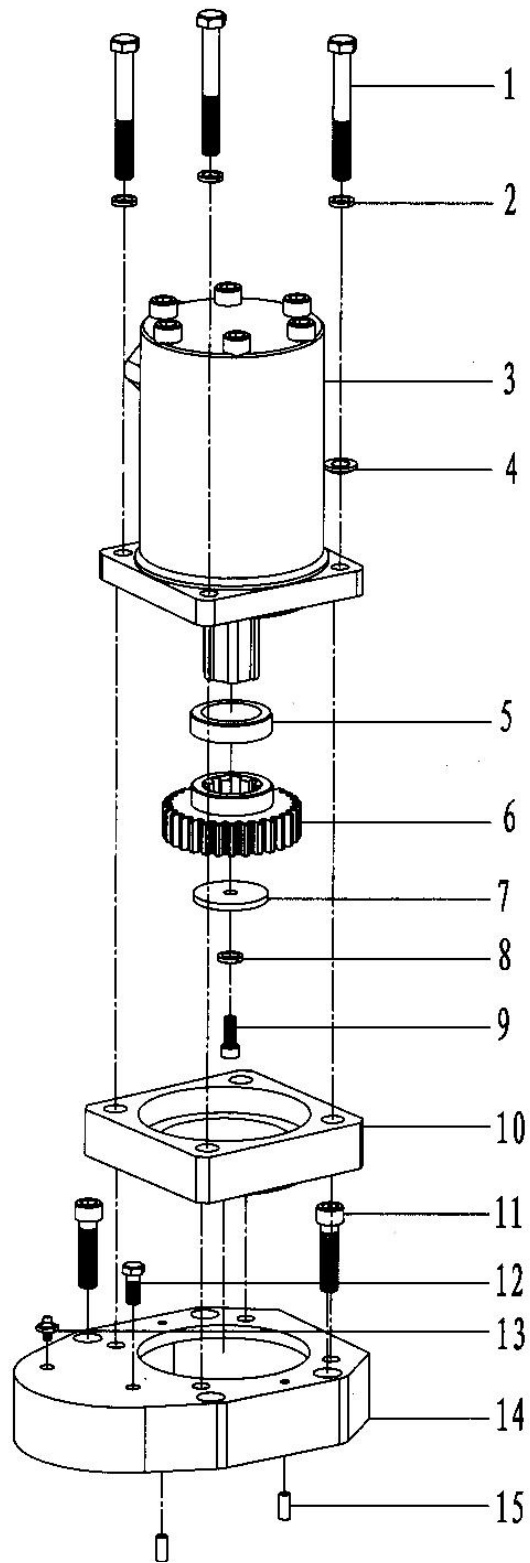

Fig. 14

Table. 9 Detailed table for Case body assembly

No.	P/N	Drawing No.	Names and specifications of parts	QTY
1	KHT8625-301		Hex bolt 1/2UNC"×3 1/4"	4
2	KHT8625-102		Spring washer 1/2"	4
3	KHT8625-304A		Cycloid hydraulic motor 6K-625(plate type)	1
	KHT8625-304B		Cycloid hydraulic motor 6K-625(tube type)	1
4	KHT8625-316	KHT13625.1.6-16	ring gasket	1
5	KHT8625-305	KHT13625.1.6-13	Washer	4
6	KHT8625-306	KHT13625.1.6-1B	Motor gear	1
7	KHT8625-307	KHT13625.1.6-15	Lock rings at the end of shaft	1
8	KHT8625-308	GB/T93	Spring washer8	1
9	KHT8625-309	GB/T70	Hex SHCS M8×25	1
10	KHT8625-310	KHT13625.1.6-14	Motor connection seat	1
11	KHT8625-311		Hexagon socket cap screw 1/2"UNC×1 3/4"	4
12	KHT8625-312		Hex bolt 3/8"UNC×1/2"	1
13	KHT8625-313		Grease cup NPT1/8"×45 °	1
14	KHT8625-314	KHT8625.1.7-1	Small case body	1
15	KHT8625-315		Cylinder pinΦ5/16"×3/4"	2

7.1.8 Hydraulic valve bank (four connection valve)(Fig.15, Table.10)

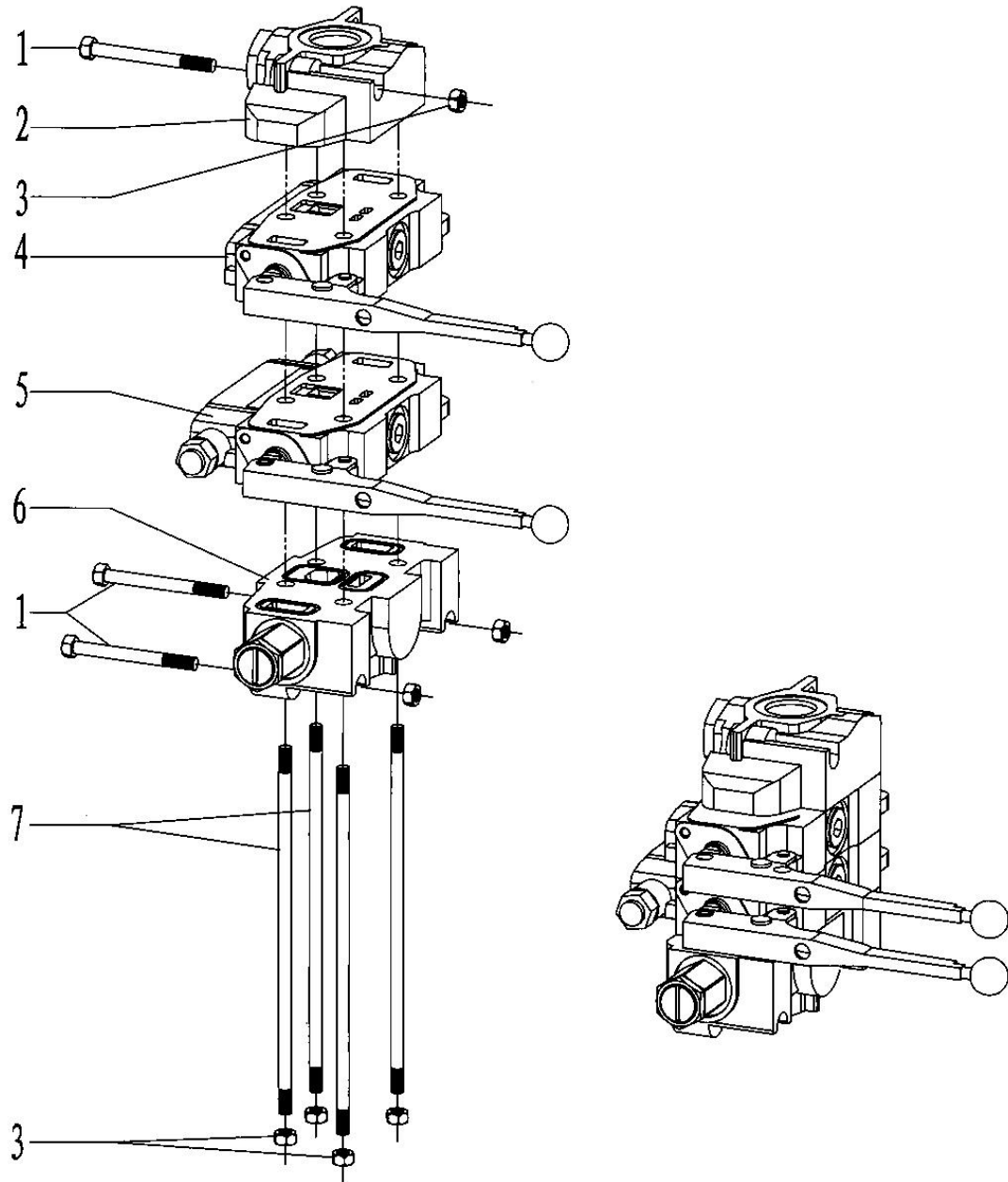

Fig. 15

Table 10. Detailed table for Hydraulic combination valve assembly

No.	P/N	Drawing No.	Names and specifications of parts	QTY
1	KHT8625-330		Hex bolt 4 1/2"×1/2"UNC	4
2	KHT8625-331		Connection board assembly	1
3	KHT8625-332		Hex nut 1/2"	8
4	KHT8625-333		Hand control valve assembly(H)	1
5	KHT8625-334		Hand control valve assembly(O)	1
6	KHT8625-335		Overflow valve assembly	1
7	KHT8625-336		Bolt 1/2"UNC	4

7.1.9 Safety door assembly(Fig.16, Table.11)

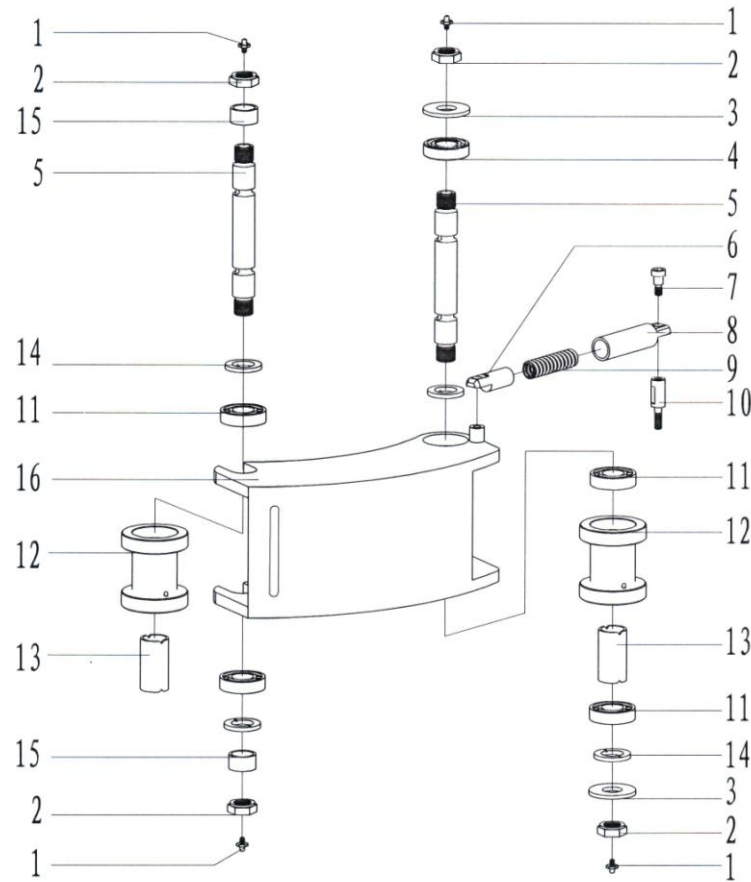

Fig. 16

Table 11. Detailed table for Safety door assembly

No.	P/N	Drawing No.	Names and specifications of parts	QTY
1	KHT8625-150		NPT1/8Grease cup	4
2	KHT8625-351		Check nut1"-12UNF	4
3	KHT8625-352	TQ508/70Y.2.1-1	Base plate	2
4	KHT8625-353	GB276	Deep groove ball bearing 6202	2
5	KHT8625-354	TQ508/70Y.9-7	Door spindle	2
6	KHT8625-355	KHT13625.1.10-5	Sleeve rod	2
7	KHT8625-356	KHT13625.1.10-1	Bolt 1	4
8	KHT8625-357	KHT13625.1.10-3	Sleeve	1
9	KHT8625-358	KHT13625.1.10-4	Spring	1
10	KHT8625-359	KHT13625.1.10-2	Sleeve fixing Pole	1
11	KHT8625-360	GB283	Roller bearing 32206E	4
12	KHT8625-361	TQ508/70Y.2.1-4	Centralizing roller	2
13	KHT8625-362	TQ508/70Y.2.1-3	Bush	2
14	KHT8625-363	TQ508/70Y.2.1-2	Washer	4
15	KHT8625-364	KHT8625.1.10-1	Sleeve	2
16	KHT8625-365	KHT8625.1.10.1	Safety door	1

7.1.10 Shifter assembly(Fig.17, Table.12)

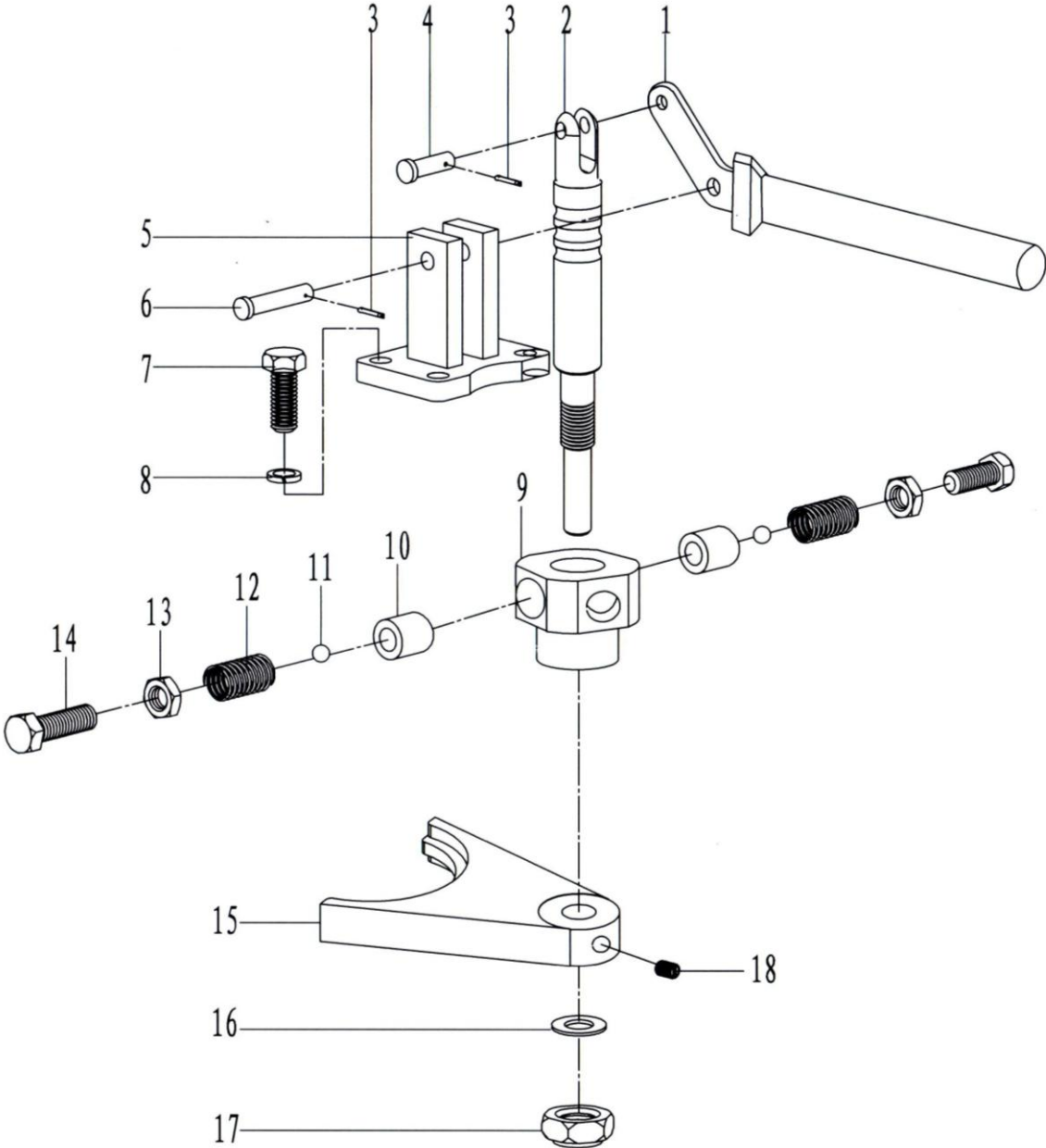

Fig. 17

Table.12 Detailed table for Shifter assembly

No.	P/N	Drawing No.	Names and specifications of parts	QTY
1	KHT8625-420	KHT9625.1.14-1	Shift fork shaft	1
2	KHT8625-421	KHT8625.1.11-1	Shifting shaft	1
3	KHT8625-422	GB/T91	Cotter pin3.2×16	2
4	KHT8625-423	GB/T882	Pin shaft 8×25	1
5	KHT8625-424	KHT13625.1.2-18	Support seat	1
6	KHT8625-425	GB/T882	Pin shaft 8×40	1
7	KHT8625-114		Hex bolt 3/8"UNC×1 1/2"	4
8	KHT8625-427		Spring washer3/8"	8
9	KHT8625-428	KHT13625.1.2-5	Shaft seat	1
10	KHT8625-429	KHT13625.1.11-3	Locating shaft sleeve	1
11	KHT8625-430		Steel ball 3/8"	1
12	KHT8625-431	KHT13625.1.11-4	Detent spring	1
13	KHT8625-432		Hex nut 7/16"UNF	1
14	KHT8625-433		Hex bolt 7/16"UNF×1 1/4"	1
15	KHT8625-434	KHT8625.1.11-2	Shifting fork	1
16	KHT8625-435		Flat washer5/8"	1
17	KHT8625-436		Lock nut 5/8"-18UNF	1
18	KHT8625-437		Hexagon socket set screw with flat point 7/16"UNC×1 1/2"	1

7.1.11 Brake band assembly(Fig.18, Table.13)

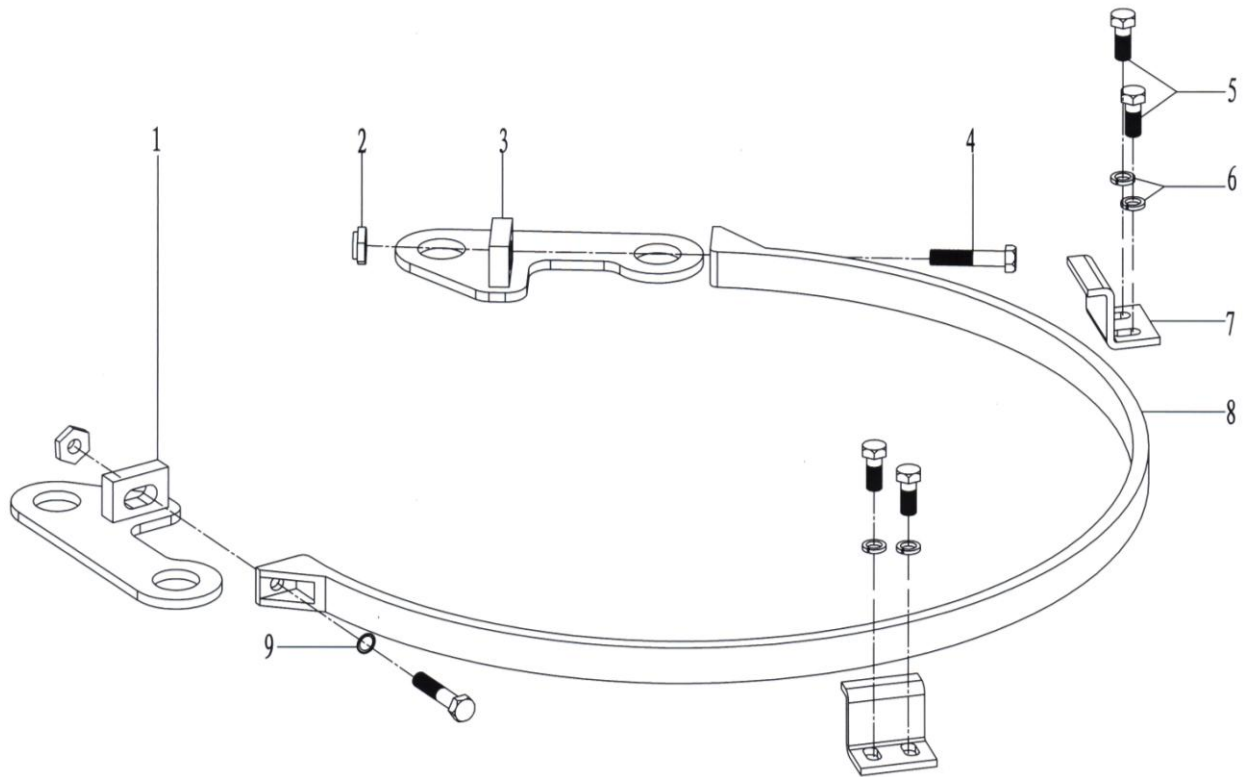

Fig. 18

Table. 13 Detailed table for Brake band assembly

No.	P/N	Drawing No.	Names and specifications of parts	QTY
1	KHT8625-451	KHT8625.1.2-9	Fixed seat(right)	2
2	KHT8625-452		Lock nut 3/8"	2
3	KHT8625-453	KHT8625.1.2-12	Fixed seat(left)	2
4	KHT8625-454		Hex bolt 3/8"UNC x2"	2
5	KHT8625-110		Hex bolt 3/8UNC" x1"	4
6	KHT8625-80		Spring washer3/8"	4
7	KHT8625-112	KHT13625.1.2-20	Restrict block	2
8	KHT8625-458	KHT8625.1.12.1	Brake band	1
9	KHT8625-459		Flat washer 3/8"	2

7.1.12 Spring lifter assembly(Fig.19, Table.14)

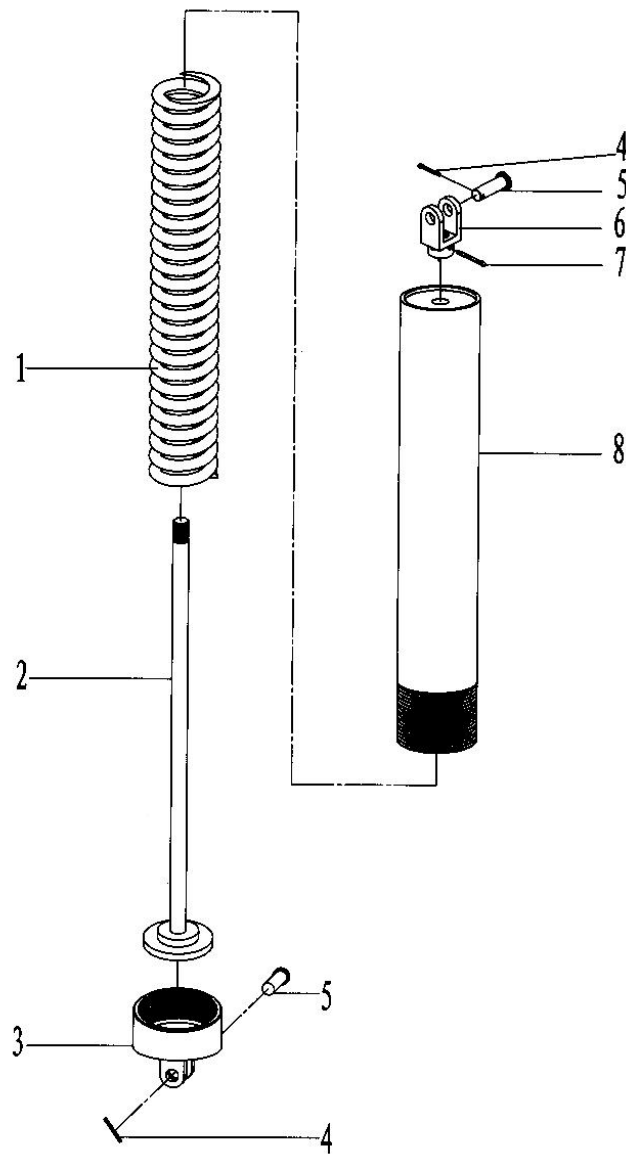

Fig. 19

Table. 14 Detailed table for Spring lifter assembly

No.	P/N	Drawing No.	Names and specifications of parts	QTY
1	KHT8625-480	TQ340/35Y.1.13-0.1	Spring	1
2	KHT8625-481	TQ340/35Y.1.13.1	Suspend rod	1
3	KHT8625-482	TQ245/20Y.1.14(2)-1	End cover	1
4	KHT8625-483	GB/T91	Cotter pin 4×40	2
5	KHT8625-484	GB/T882	Pin shaft 20×60	2
6	KHT8625-485	XYQ12.YD-01.1	Suspend head	1
7	KHT8625-486	GB/T91	Cotter pin 4×50	1
8	KHT8625-487	TQ340/35Y.1.13(2).1	Spring lifter	1

7.1.13 Suspending rod assembly (Fig. 20, Table. 15)

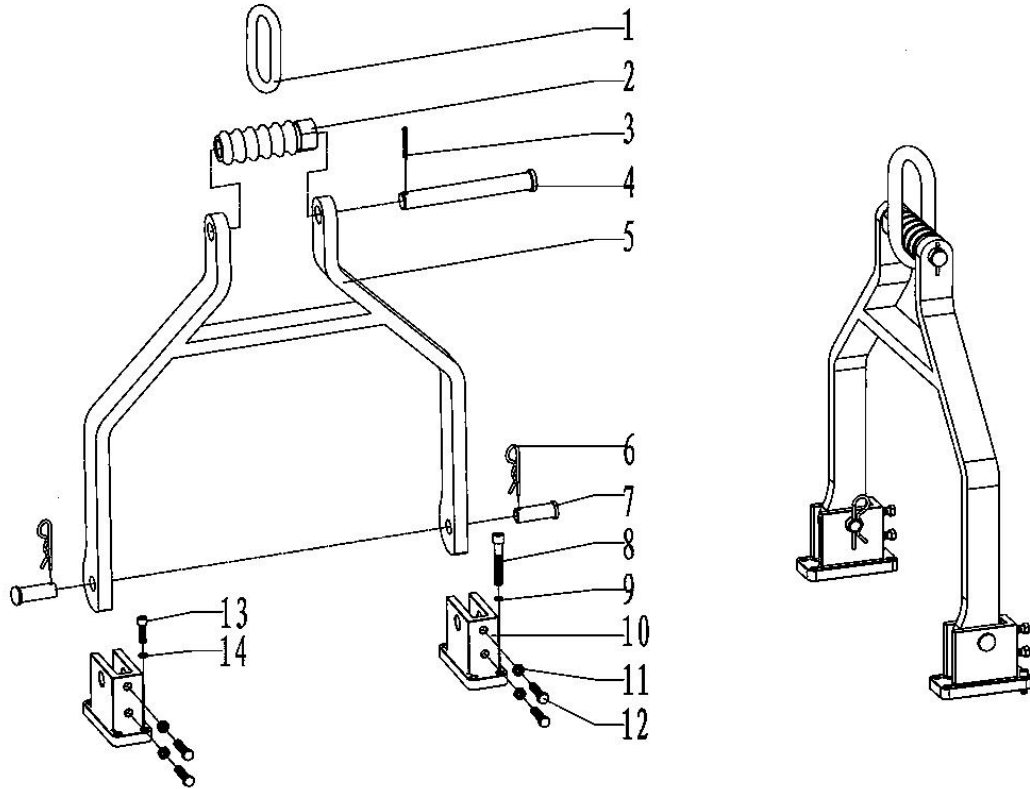

Fig. 20

Table. 15 Detailed table for Suspending rod assembly

No.	P/N	Drawing No.	Names and specifications of parts	QTY
1	KHT8625-500		Flying ring(5T)	1
2	KHT8625-501	TQ245.15(2)-1	Screw bar	1
3	KHT8625-502	GB/T91	Cotter pin 6×45	1
4	KHT8625-503	TQ245.15(2)-2	Pin shaft	1
5	KHT8625-504	KHT8625.1.13.1	Suspending rod	1
6	KHT8625-505	TQ245-2	Circlip	2
7	KHT8625-506	GB/T882	Pin shaft B25×90	2
8	KHT8625-507		Hex SHCS 3/8"×2 1/4"	4
9	KHT8625-80		Spring washer 3/8"	4
10	KHT8625-509	KHT8625.1.13-1	Suspend seat	2
11	KHT8625-510		Hex nut 1/2"	2
12	KHT8625-511		Hex bolt 1/2"×2"	2
13	KHT8625-512		Hexagon socket cap screw 1/2"×1 1/2"	4
14	KHT8625-64		Spring washer 1/2"	4

7.1.14 Support roller(Fig.21, Table.16)

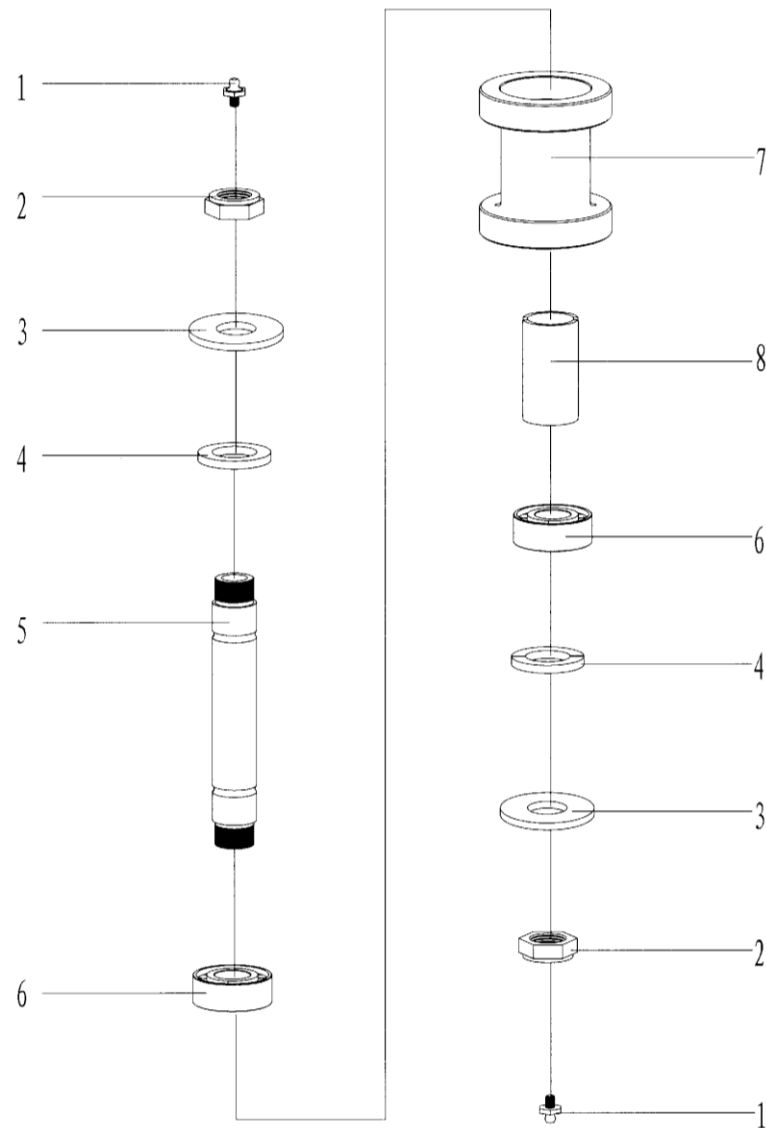

Fig. 21

Table.16 Detailed table for Support roller

No.	P/N	Drawing No.	Names and specifications of parts	QT Y
1	KHT8625-530	GB1152	Grease cup M6	2
2	KHT8625-531	TQ508/70Y.2.1.1	1"-12UNF nylock nut	2
3	KHT8625-532	TQ508/70Y.2.1-1	Plain washer	2
4	KHT8625-352	TQ508/70Y.2.1-2	Roller bearing spacer	2
5	KHT8625-363	TQ508/70Y.2.1-5	Support roller shaft	1
6	KHT8625-533	GB/T281-1994	Support roller bearing 1206TN1	2
7	KHT8625-361	TQ508/70Y.2.1-4	Support roller	1
8	KHT8625-362	TQ508/70Y.2.1-3	Support roller spacer	1

7.1.15 Hydraulic valve bank assembly(Fig.22, Table.17)

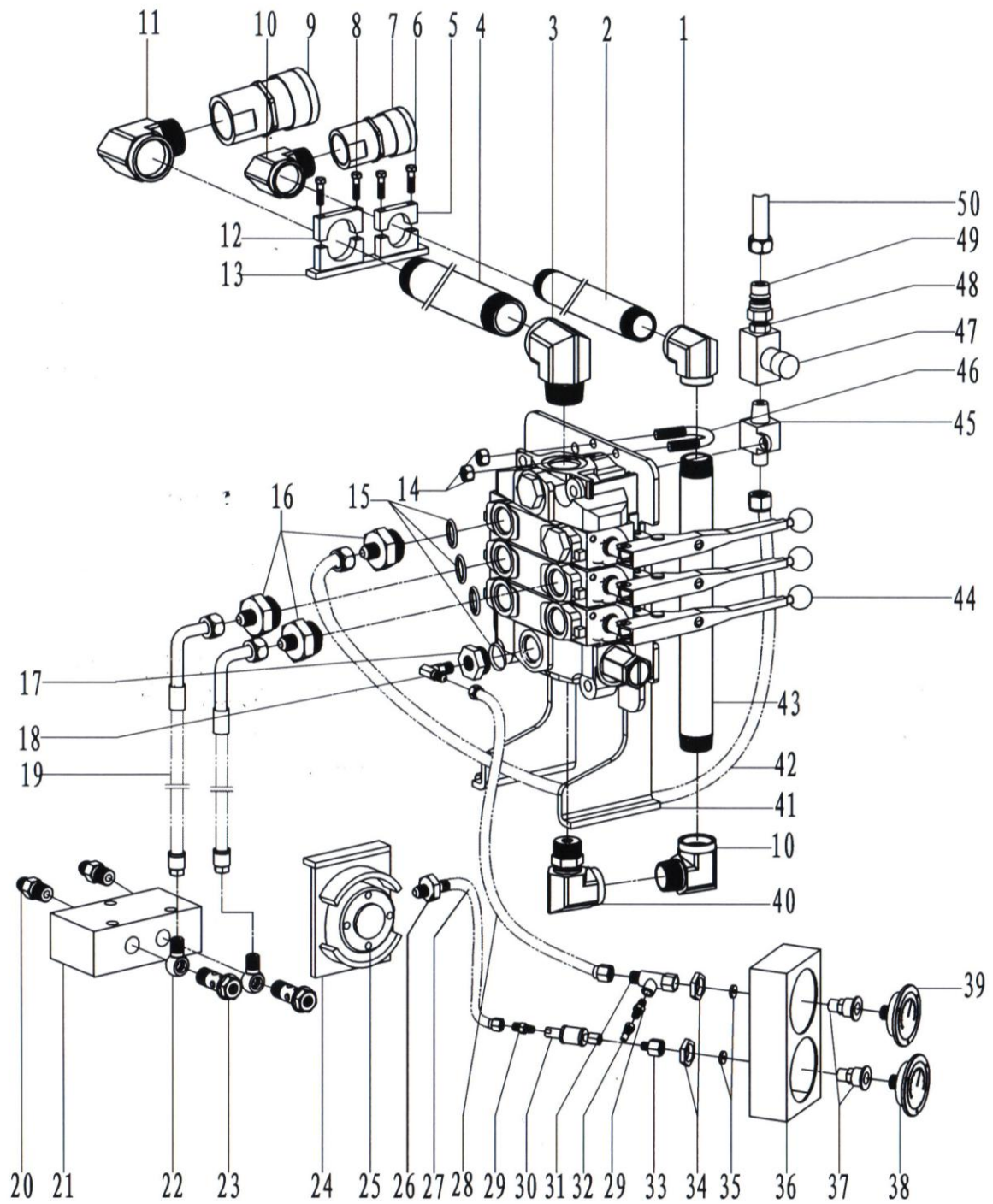

Fig. 22

Table. 17 Detailed table for Hydraulic valve bank assembly

No.	P/N	Drawing No.	Names and specifications of parts	QTY
1	KHT8625-617	KJD9625.18-10	Elbow adaptor NPT1	1
2	KHT8625-620	KJD9625.18-9	Oil tube (NPT1)	1
3	KHT8625-577	KJD9625.18.5	Elbow adaptor (NPT1 1/4 inner-1 5/8-12UN outer)	1
4	KHT8625-568	KJD9625.18-6	Tube(NPT1 1/4)	1
5	KHT8625-569	KJD9625.18.7-1	Upper jacket (1)	1
6	KHT8625-571	GB/T5782	Hexagon boltM8×45	2
7	KHT8625-570	KJD9625.18.4	Quick coupling(1 7/8-12UN)	1
8	KHT8625-624	GB/T5782	Hexagon boltM8×55	2
9	KHT8625-572	KJD9625.18.3	Quick coupling(2 1/8-12UN)	1
10	KHT8625-573	KJD9625.18-8	Elbow adaptor (NPT1)	2
11	KHT8625-574	KJD9625.18-7	Elbow adaptor (NPT1 1/4)	1
12	KHT8625-575	KJD9625.18.7-5	Upper pipe clamp (2)	1
13	KHT8625-576	KJD9625.18.7-2	Lower pipe clamp (1)	1
14	KHT8625-452		Lock nut 3/8"	2
15	KHT8625-582	As568	O Ring 29.75×2.75	2
16	KHT8625-583	KHT5500.1.8-6	Adaptor (1 5/16-12UN-3/4-UNF)	3
17	KHT8625-586	TQ508/70Y.10-10	Adaptor 1 5/16	1
18	KHT8625-588	TQ508/70Y.10.10	Small combined adaptor 7/16-20UNF	1
19	KHT8625-589		Hose 10 II -1600(3/4-16UNF Both ends flaring type, two ends 90° in the same plane different direction)	2
20	KHT8625-591	YG-45	Adaptor(M18×1.5-3/4UNF)	2
21	KHT8625-592	KHT9625.2.7	Hydraulic control one-way valve	1
22	KHT8625-593	YG-46	Ball connector	2
23	KHT8625-594	XYQ.3C-21	Oil passing bolt	2
24	KHT8625-608	KHT5500.2.8	Torque cylinder connected seat	1
25	KHT8625-609		Pressure cylinder(60)	1
26	KHT8625-633	YG-14	Adaptor(NPT1/4-9/16-18UNF)	
27	KHT8625-611		Hose 6 II -1300 (NPT1/4-9/16-18UNF)	1
28	KHT8625-595		Hose 6 II -900(M20×1.5-7/16UNF Flaring type)	1
29	KHT8625-596	YG-82	Adaptor NPT1/4-M20×1.5	1
30	KHT8625-597		Quick Combined adaptor (both ends are internal threads on NPT1/4")	1
31	KHT8625-625	KHT5500.1.8.1-1	Oil filled tee joint	1
32	KHT8625-626	YG-68	Adaptor NPT1/4"	2

32	KHT8625-627	YG-52	Adapter connector (M20-NPT1/4)	1
33	KHT8625-628	KJD9625.11 (2) -2	And the nut	2
34	KHT8625-629		Teflon washer	2
35	KHT8625-630	KJD9625.11 (2)	Pressure gauge seat	1
36	KHT8625-631	KJD9625.11 (2) -1	Attchment connector	2
37	KHT8625-632		Torque gaugeYN100ZT(0-30000ft.lb)	1
38	KHT8625-603		Pressure gaugeY-60ZT(0-3600PSI)	1
39	KHT8625-604	KJD9625.18.6	Elbow adaptor(NPT1inner-1 5/16-12UN outer)	1
40	KHT8625-605	KHT5500.1.18.1(2)	Valve connection assembly	1
41	KHT8625-606		Hose 10 II -850(3/4-16UNF Both ends flaring type, one end 90 °)	1
42	KHT8625-607	KJD9625.18-9(2)	Oil tube(NPT1)	1
43	KHT8625-612	VG35-3-004	Multi-way valve assembly(Parker)	1
44	KHT8625-614	KHT9625.1.9-2	Adaptor (NPT1/2-3/4UNF)	1
45	KHT8625-615	KJD9625-5	U-bolt	1
46	KHT8625-616	DV10	Throttle valve	1
47	KHT8625-618	KHT5500.1.15D-2	Adaptor NPT1/2-M24×1.5	1
48	KHT8625-619		Quick couplingM24×1.5	1
49	KHT8625-621		Hose10 II -2500(one end3/4-16UNF Flaring type ,90 °, one end M24×1.5)	1

7.1.16 Quick exchange adaptor (2 1/8-12UN)(Fig.23, Table.18)

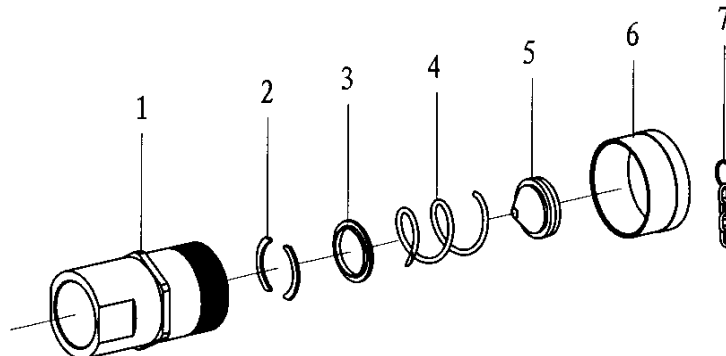

Fig. 23

Table 18 Detailed table for Quick exchange adaptor (2 1/8-12UN)

No.	P/N	Drawing No.	Names and specifications of parts	QTY
1	KHT8625-640	KJD9625.18.3-2	Adaptor body	1
2	KHT8625-641	KJD9625.18.3-5	Clip	2
3	KHT8625-642	KJD9625.18.3-4	Washer	1
4	KHT8625-643	KJD9625.18.3-3	Spring	1
5	KHT8625-644	KJD9625.18.3.1	Core	1
6	KHT8625-645	KJD9625.18.3-1	End cover	1
7	KHT8625-646	KJD9625.18.3.2	Combination chain	1

7.1.17 Quick exchange adaptor (1 7/8-12UN) (Fig.24, Table.19)

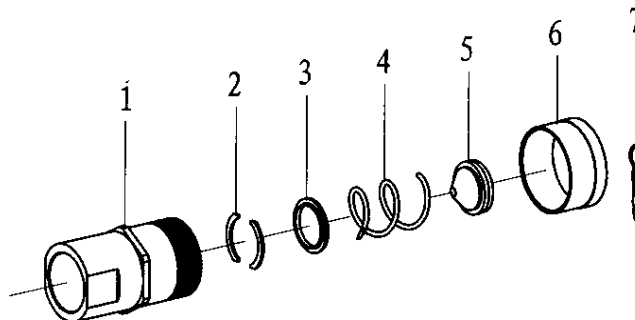

Fig. 24

Table. 19 Detailed table for Quick exchange adaptor (1 7/8-12UN)

No.	P/N	Drawing No.	Names and specifications of parts	QTY
1	KHT8625-640	KJD9625.18.3-2	Adaptor body	1
2	KHT8625-641	KJD9625.18.3-5	Clip	2
3	KHT8625-642	KJD9625.18.3-4	Washer	1
4	KHT8625-643	KJD9625.18.3-3	Spring	1
5	KHT8625-660	KJD9625.18.3.1	Core	1
6	KHT8625-645	KJD9625.18.3-1	End cover	1
7	KHT8625-646	KJD9625.18.3.2	Combination chain	1

7.1.18 Safety protection device (Fig.25, Table.20)

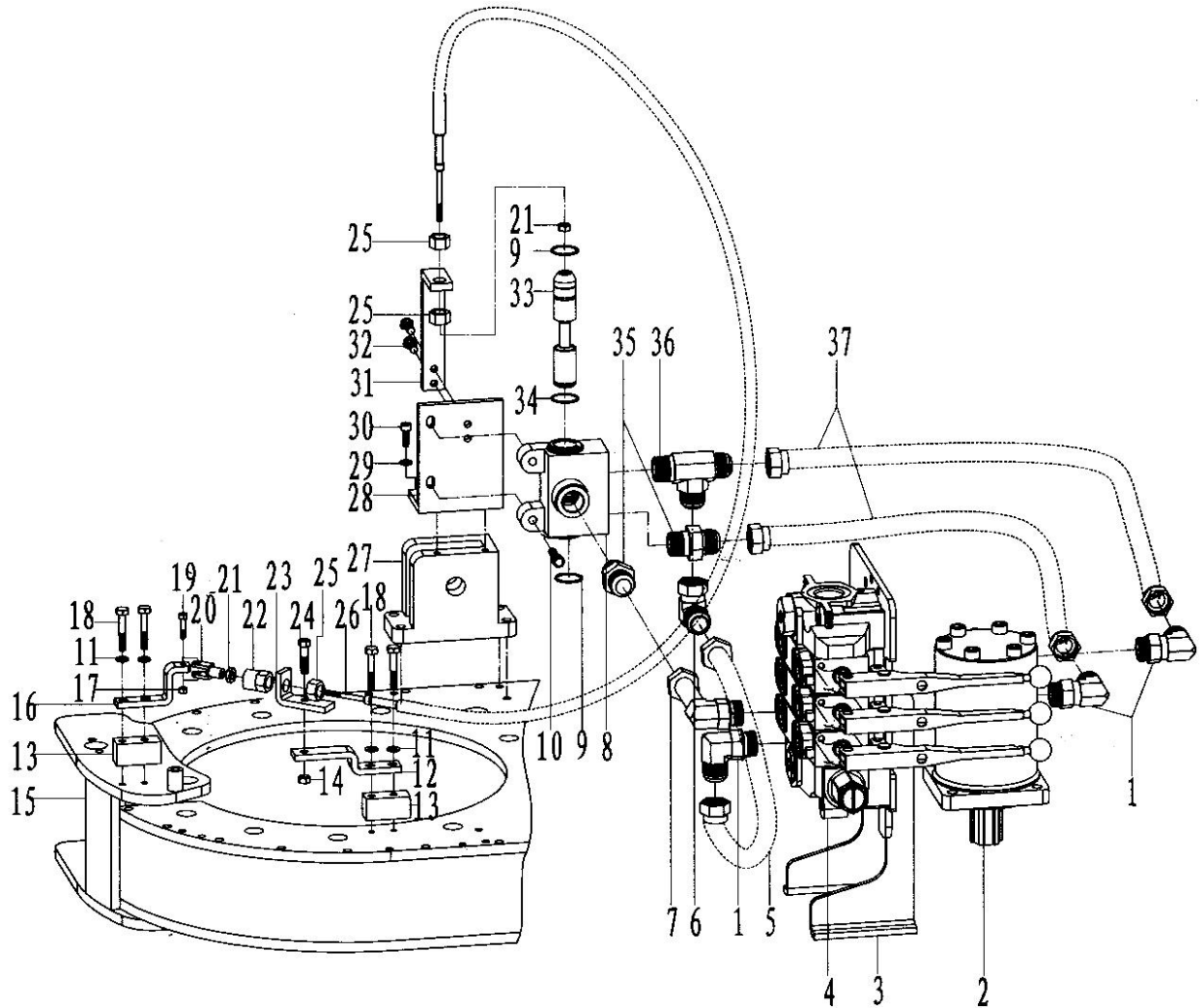

Fig. 25

Table. 20 Detailed table for Safety protection device

No.	P/N	Drawing No.	Names and specifications of parts	QTY
1	KHT8625-587	TQ508/70Y.10.8.3	Combined adaptor	3
2	KHT8625-613		6K-625 orbit hydraulic motor (tubular connection)	1
3	KHT8625-605	KHT5500.1.18.1(2)	Valve connection assembly	1
4	KHT8625-612	VG35-3-004	Five-way valve assembly(Parker)	1
5	KHT8625-704	KHT5500.1.15D-1	Elbow hose 1 5/16-12UNC, 290×80	1
6	KHT8625-584	TQ508/70Y.10.8.4	Oil return connector 1 5/16-12UN	1
7	KHT8625-585	KJD9625.18.2(2)	Elbow adaptor 1 5/16-12UNC	1
8	KHT8625-707	RHF-1	Valve body	1
9	KHT8625-708	GB/T89.4.1	Circlip for shaft 30	2
10	KHT8625-79		Hexagon bolt 3/8-16UNC×2 1/2	2
11	KHT8625-710		Spring washer 5/16"	4

12	KHT8625-711	KHT5500.1.15C.1-5	Connection plate 2	1
13	KHT8625-712	KHT5500.1.15C.1-1	Base plate	2
14	KHT8625-713		Hexagon nut 3/8"-16UNC	3
15	KHT8625-714	KHT5500.1.10.2	Safety door	1
16	KHT8625-715	KHT5500.1.15C.1-2	Connection plate 1	1
17	KHT8625-716		Hexagon nut 1/4"-20UNC	1
18	KHT8625-717		Hexagon bolt 5/16"-18UNC×2"	4
19	KHT8625-718		Hexagon bolt 1/4"-20UNC×1 1/2"	1
20	KHT8625-719	KHT5500.1.15C.1-3	Universal joint	1
21	KHT8625-720		Hexagon bolt 1/4"-28UNC	2
22	KHT8625-721	XQ4.5.Z.6-6	Protective sleeve	1
23	KHT8625-722	KHT5500.1.15C.1-4	Rotary plate	1
24	KHT8625-723		Hexagon bolt 3/8"-16UNC×3/4"	1
25	KHT8625-724		Hexagon nut 5/8"-18UNF	3
26	KHT8625-725	173-LTT-1-71	Flexible shaft	1
27	KHT8625-509	KHT8625.1.13-1B	Suspension support	2
28	KHT8625-727	KHT5500.1.15D.1-1	Valve fixing plate (2)	1
29	KHT8625-728	KHT5500.1.15C.1-10	Washer	2
30	KHT8625-309	GB/T70	Hexagon socket cap screw M8×25-8.8	2
31	KHT8625-730	KHT5500.1.15C.1-6	Valve fixing plate 1	1
32	KHT8625-79		Hexagon bolt 3/8"-16UNC×2 1/2"	2
33	KHT8625-732	RHF-2	Valve core	1
34	KHT8625-733	GB/T3452.1	O-ring 25×2.65	1
35	KHT8625-580	KHT5500.1.15C.1-9	Adaptor 1 5/16-12UN-NPT1	2
36	KHT8625-579	KHT5500.1.15C.1-8	Three-way adaptor (NPT1-1 5/16-12UN)	1
37	KHT8625-578		High-pressure hose 25 II -800 (1 5/16-12UNC)	2

7.2 Backup Tong assembly (Fig.26, Table.21)

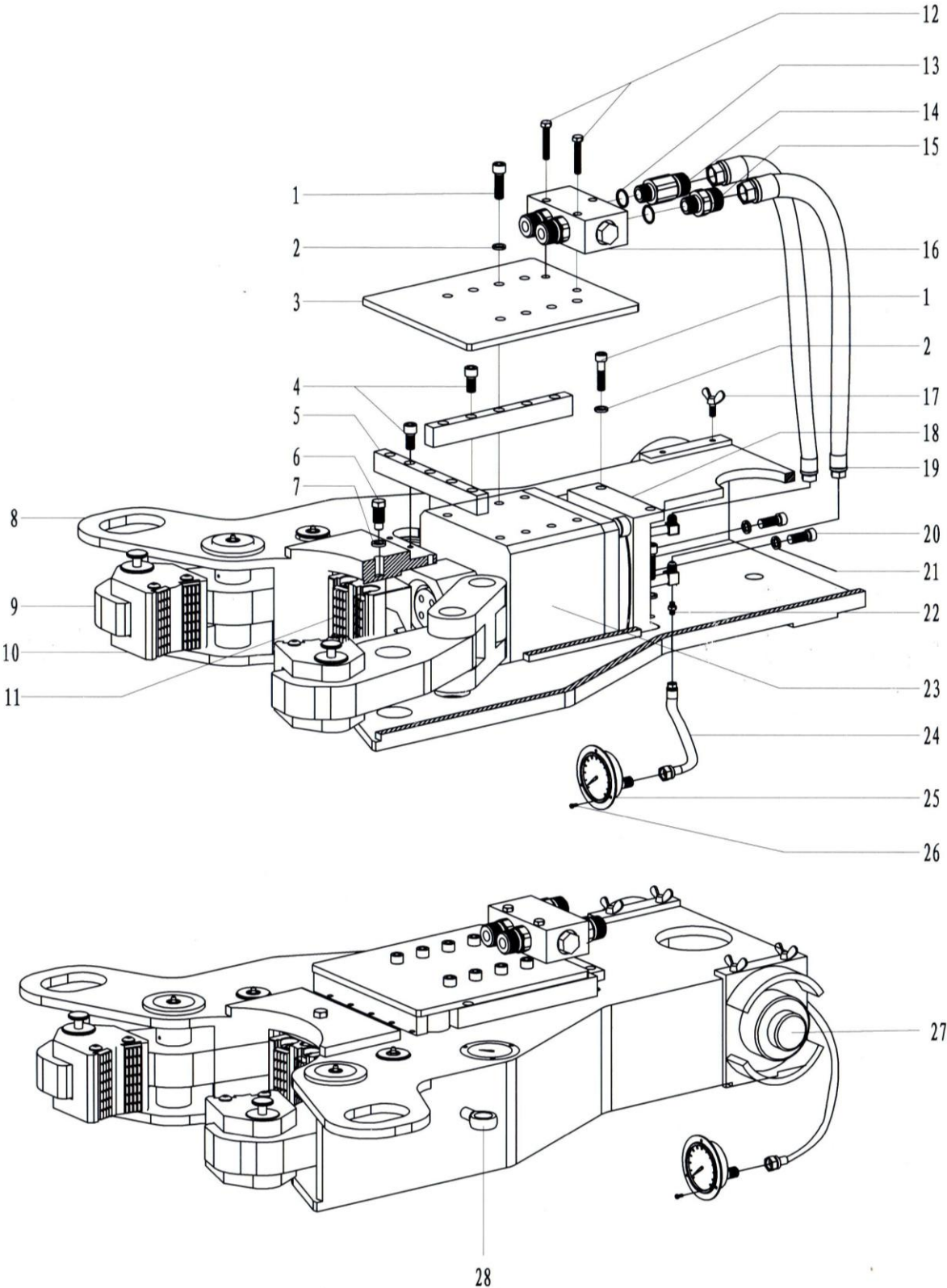

Fig. 26

Table.21 Detailed table for Backup Tong assembly.

No.	P/N	Drawing No.	Names and specifications of parts	QTY
1	KHT8625-759		Hexagon socket cap screw 1/2"×1 1/4"	14
2	KHT8625-64		Spring washer1/2"	14
3	KHT8625-757	KHT9625.2-8	Cover plate	1
4	KHT8625-756		Hexagon socket cap screw 5/16"×3/4 "	15
5	KHT8625-754	KHT8625.2-1	Base plate1	3
6	KHT8625-755	KHT9625.2-9B	Stop Bolt	1
7	KHT8625-753		Spring washer5/8"	1
8	KHT8625-752	KHT8625.2..1	Backup tong body	1
9	KHT8625-750	KHT9625.2.1B	Clamping arm	2
10	KHT8625-751	KHT8625.2.2	Front jaw set assembly	2
11	KHT8625-772	KHT9625.2.5	Rear Jaw set assembly	1
12	KHT8625-761		Hexagon socket cap screw 3/8"×2 3/4"	2
13	KHT8625-773		O Ring 22×2.4	2
14	KHT8625-774	YG-45B	Adaptor (M18×1.5-3/4UNF)	1
15	KHT8625-775	YG-45	Adaptor (M18×1.5-3/4UNF)	3
16	KHT8625-776	SYS-L15H	Pilot-controlled check valve	1
17	KHT8625-777	KHT5500.2.10	Dish bolt	1
18	KHT8625-764	KHT9625.2-7B	Baffle	1
19	KHT8625-762		Hose 10 II -900(3/4"-16UNF, flared type 74 ⁰ , one end 90 ⁰)	2
20	KHT8625-765		Hexagon socket cap screw 3/4"×2"	2
21	KHT8625-766		Spring washer3/4"	2
22	KHT8625-778	PT-3	PT test plug; (M14×1.5-M16)	
23	KHT8625-767	KHT9625.2.6B	Clamping Cylinder	1
24	KHT8625-768		HF H2-P1-3-P-600	2
25	KHT8625-769		Pressure gaugeY-60ZT(0-2320PSI)	1
26	KHT8625-770		Cross recess head screw 1/4"×1/2"	3
27	KHT8625-779	KHT8625.2.3	Torque testing assembly	1
28	KHT8625-771	GB/T825	Lock Nut M12	2

7.2.1、Backup Tong Transmission assembly (Fig.27, Table.22)

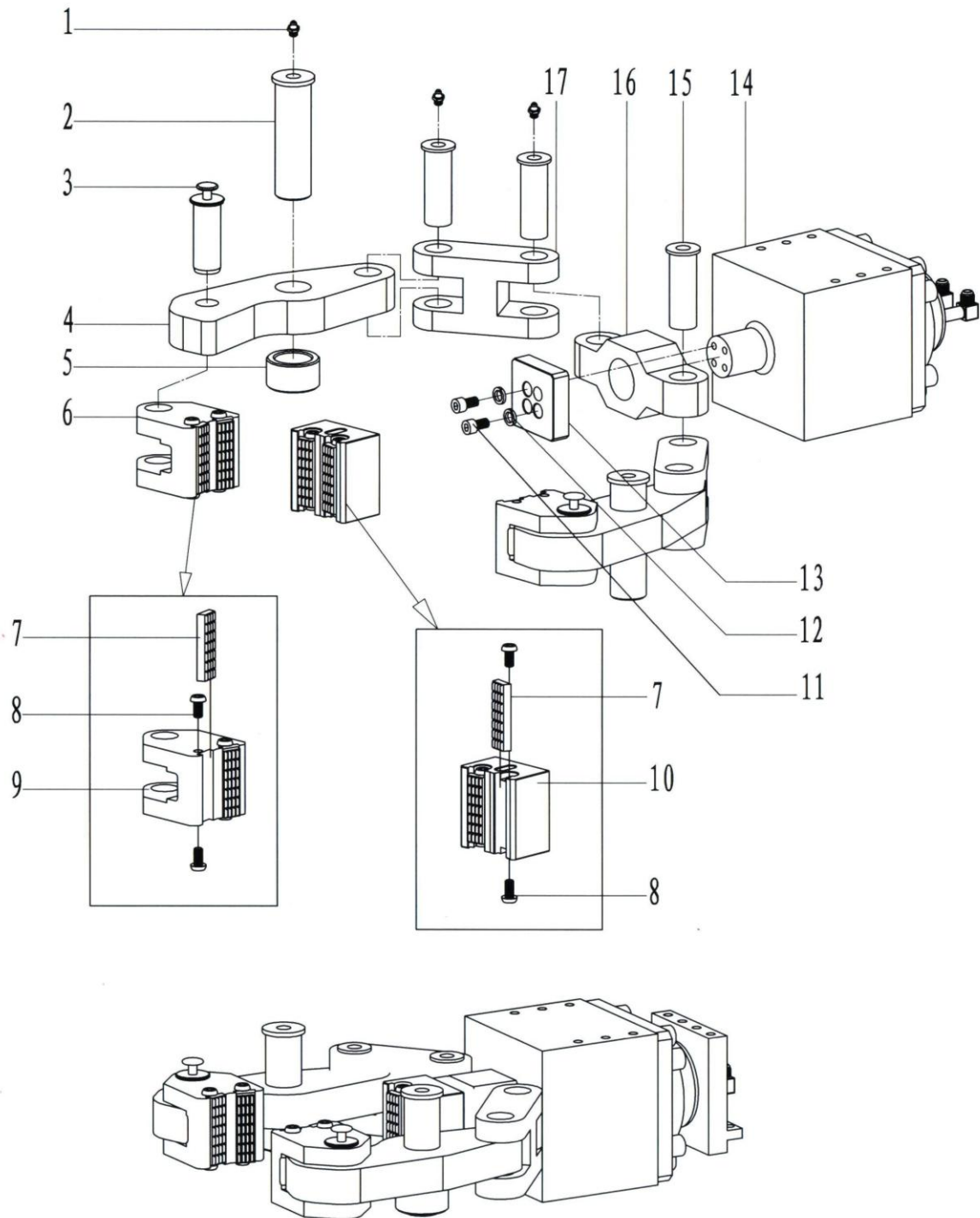

Fig. 27

Table.22 Detailed table for Backup Tong Transmission assembly

No.	P/N	Drawing No.	Names and specifications of parts	QTY
1	KHT8625-530	GB/T1152	Grease cup M6×1	6
2	KHT8625-791	KHT9625.2-1B	Turning Axle	2
3	KHT8625-792	KHT9625.2-2B	Fixed Pin	2
4	KHT8625-793	KHT9625.2.1B	Clamping arm	2
5	KHT8625-794	KHT9625.2-20B	Lining ring	2
6	KHT8625-795	KHT8625.2.2	Front jaw set assembly	2
7	KHT8625-91	KHT9625.1.1.1-2	Die1 ~ 11	Each12
8	KHT8625-797		Hexagon socket cap screw 1/2"×1"	12
9	KHT8625-799	KHT8625.2.2-1(3)	Front Jaw set3(8 5/8")	Each2
	KHT8625-800	KHT8625.2.2-1(4)	Front Jaw set4(7 5/8")	Each2
	KHT8625-801	KHT8625.2.2-1(6)	Front Jaw set6(5 1/2")	Each2
	KHT8625-802	KHT8625.2.2-1(7)	Front Jaw set7(4 1/2")	Each2
	KHT8625-803	KHT8625.2.2-1(8)	Front Jaw set8(3 1/2")	Each2
	KHT8625-804	KHT8625.2.2-1(9)	Front Jaw set9(2 7/8")	Each2
	KHT8625-805	KHT8625.2.2-1(10)	Front Jaw set10(7")	Each2
	KHT8625-806	KHT8625.2.2-1(11)	Front Jaw set11(5")	Each2
10	KHT9625-808	KHT9625.2.5-1B(3)	Rear Jaw set3(8 5/8")	Each1
	KHT8625-809	KHT9625.2.5-1B(4)	Rear Jaw set4(7 5/8")	Each1
	KHT8625-810	KHT9625.2.5-1B(6)	Rear Jaw set6(5 1/2")	Each1
	KHT8625-811	KHT9625.2.5-1B(7)	Rear Jaw set7(4 1/2")	Each1
	KHT8625-812	KHT9625.2.5-1B(8)	Rear Jaw set8(3 1/2")	Each1
	KHT8625-813	KHT9625.2.5-1B(9)	Rear Jaw set9(2 7/8")	Each1
	KHT8625-814	KHT9625.2.5-1B(10)	Rear Jaw set10(7")	Each1
	KHT8625-815	KHT9625.2.5-1B(11)	Rear Jaw set11(5")	
11	KHT8625-816		Hexagon socket cap screw 3/8"×1"	4
12	KHT8625-817		Spring washer3/8"	4
13	KHT8625-818	KHT9625.2-5	Plate pinch	1
14	KHT8625-819	KHT9625.2.6	Clamping Cylinder	1
15	KHT8625-820	KHT9625.2-4B	Pin shaft2	2
16	KHT8625-821	KHT9625.2-6B	Connecting Seat	1
17	KHT8625-822	KHT9625.2-3B	Connecting Rod	2

7.2.2 Clamping cylinder assembly (Fig.28, Table.23)

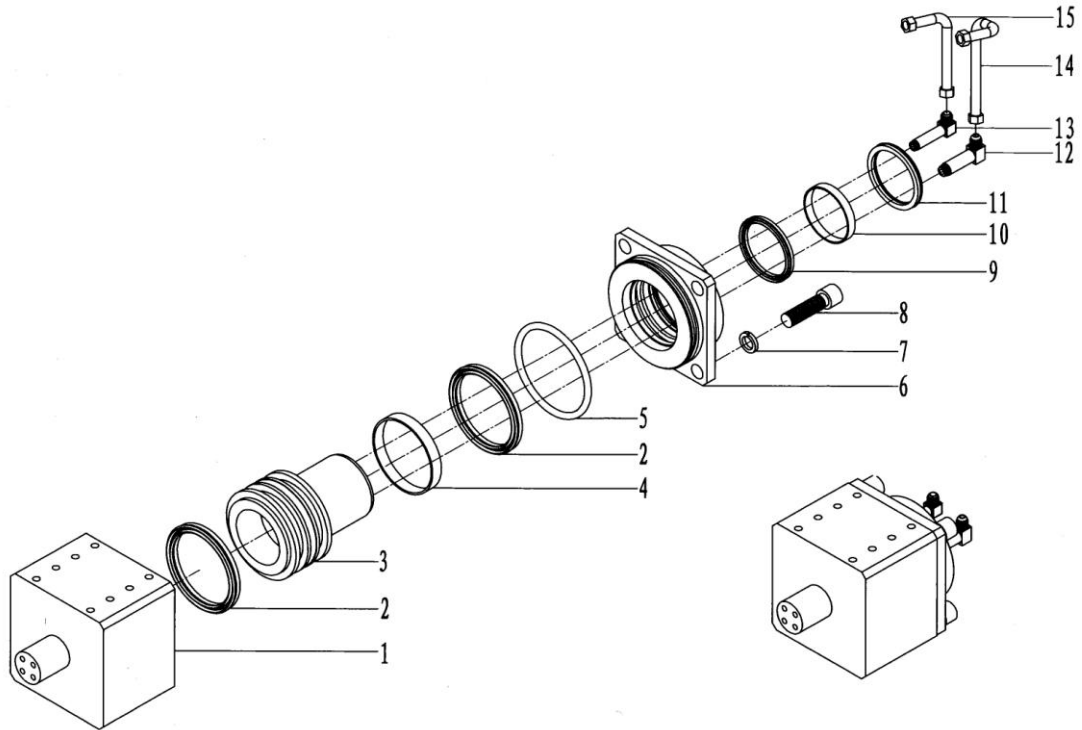

Fig. 28

Table.23 Detailed table for Clamping cylinder assembly

No.	P/N	Drawing No.	Names and specifications of parts	QTY
1	KHT8625-850	KHT9625.2.6-1B	Clamping cylinder	1
2	KHT8625-851	GB/T10708.1	Y O-Ring180×150×18	2
3	KHT8625-852	KHT9625.2.6-2B	Piston	1
4	KHT8625-853	GB/T15242.2	Support Ring SD1800C- II A	1
5	KHT8625-854	GB/T3452.1	O-Ring 165×7	1
6	KHT8625-855	KHT9625.2.6-3B	Cylinder Cover	1
7	KHT8625-856		Spring washer24	8
8	KHT8625-857		Hexagon Socket Head Screw M24	8
9	KHT8625-858	GB/T10708.1	Y Ring 125×145×14.5	1
10	KHT8625-859	GB/T15242.2	Support Ring GD 1250B- II A	1
11	KHT8625-860	GB/T10708.3	Dustproof RingFA125×140×9.5	1
12	KHT8625-861	KHT9625.2.6-5	Angle coupling	1
13	KHT8625-862	KHT9625.2.6-6B	Angle coupling (2)	1
14	KHT8625-863	KHT9625.2.6.1	Hard tube 2	1
15	KHT8625-864	KHT9625.2.6.2	Hard tube 1	1

7.3 Lifting Chain Assembly (Fig.29, Table.24)

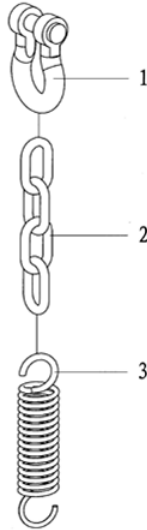

Fig. 29

Table.24 Detailed table for Lifting Chain Assembly

No.	P/N	Drawing No.	Names and specifications of parts	QTY
1	KHT8625-880	JB/T8112	Shackle M-BX5 (φ12)	1
2	KHT8625-881	JB/T8108.2	Chainφ8 (L=600)	1
3	KHT8625-882	KHT8625.3-1	Tension Spring	1

7.4 Front guide pole Assembly (Fig.30, Table.25)

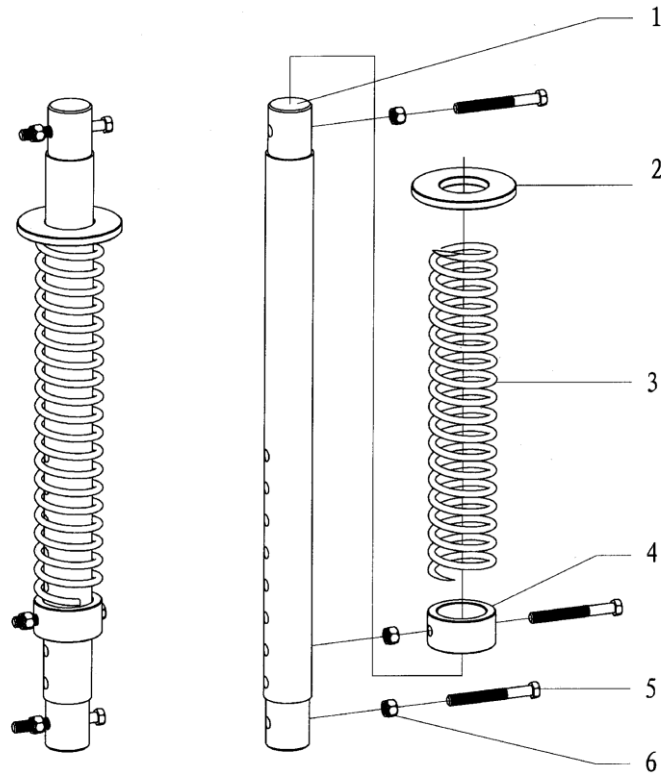

Fig. 30

Table.25 Detailed table for Front guide pole Assembly

No.	P/N	Drawing No.	Names and specifications of parts	QTY
1	KHT8625-890	KHT9625.5-1B	Front guide pole	1
2	KHT8625-891	KJD9625.Q-2	Washer	1
3	KHT8625-892	KHT9625.5-2B	Spring of Front guide pole	1
4	KHT8625-893	KJD9625.Q -4	Stationary Bushing	1
5	KHT8625-894		Hex Bolt 1/2"×4"	3
6	KHT8625-151		Hex Locknut 1/2"	3

7.5. Hydraulic spring suspending device (Fig.31, Table.26)

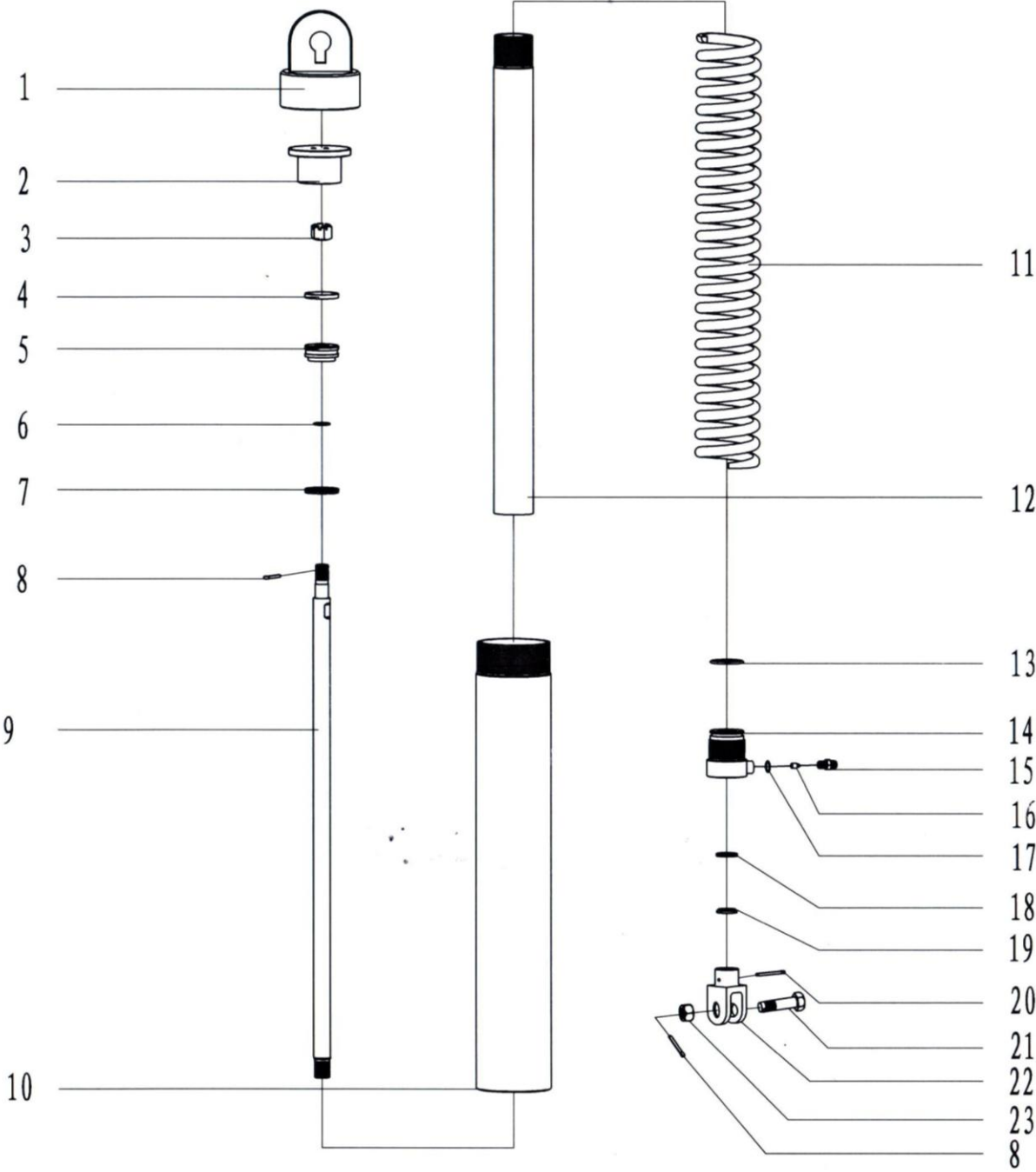

Fig.31

Table. 26 Detailed table for Hydraulic spring suspending device

No.	P/N	Drawing No.	Names and specifications of parts	QT Y
1	KHT8625-910	TQ340/35YA.1.16.3	Bucket end joint	1
2	KHT8625-911	TQ340/35YA.1.16-6	Cylinder end joint ²	1
3	KHT8625-912	GB/T6178	Slotted NutM30	1
4	KHT8625-913	GB/T15242.2	SD 0630- II A	1
5	KHT8625-914	KT340/35YA.1.16-5	Piston	1
6	KHT8625-915	GB/T3452.1	O-Ring32.5×3.55	1
7	KHT8625-916	GB/T10708.1	Y-RingY80×65×9.5	1
8	KHT8625-917	GB/T91	Cotter pin 6.3×50	2
9	KHT8625-918	TQ340/35YA.1.16-4	Piston Rod	1
10	KHT8625-919	TQ340/35YA.1.16.2	Bucket body	1
11	KHT8625-920	TQ340/35YA.1.16-2	Spring	1
12	KHT8625-921	TQ340/35YA.1.16-3	Cylinder body	1
13	KHT8625-922	GB/T3452.1	O-Ring 56×3.55	1
14	KHT8625-923	TQ340/35YA.1.16.1	Cylinder end joint 1	1
15	KHT8625-924	XYQ12.YD-01.2	Adaptor	1
16	KHT8625-925	XYQ12.YD-01.3	Throttle spool	1
17	KHT8625-926	GB/1235	O-Ring 24×2.4	1
18	KHT8625-927	GB/T10708.1	Y-RingY40×50×6.3	1
19	KHT8625-928	GB/T10708.3	Dustproof RingFA40×48×5	1
20	KHT8625-929	GB/T91	Hexagon nut M30	1
21	KHT8625-930	TQ340/35YA.1.16-7	Pin shaft	1
22	KHT8625-931	TQ340/35YA.1.16-1	Cotter pin 6.3×80	1
23	KHT8625-932	GB/T41	Hexagon nut	1

8.quick-wear part

Table of quick-wearing or spare parts(recommended for the one-year storage of one tong actual figures may vary according to the purchase period and the optional pieces)

No.	P/N	Drawing No.	Names and specifications of parts	QTY
1	KHT8625-91	KHT9625.1.1.1-2(2)	Die 2(1/2)	200
2	KHT8625-92	KHT8625.1.1.1-3	Roller shaft	2
3	KHT8625-93	KHT8625.1.1.1-2	Roller	2
4	KHT8625-87	KJD9625.2.1	Centralizing roller	50
5	KHT8625-89	KHT8625.1.1-7	Reverse shaft	1
6	KHT8625-112	KHT13625.1.2-20	Restrict block	2
7	KHT8625-582	As568	O-ring 29.75×2.75	2
8	KHT8625-238		Needle 1/8"×3/7"	124
9	KHT8625-600		Teflon washer	1
10	KHT8625-733	GB/T3452.1	O-ring 25×2.65	1
11	KHT8625-755	KHT9625.2-9B	Stop Bolt	1
12	KHT8625-851	GB/T10708.1	Y-ring 180×150×18	2
13	KHT8625-853	GB/T15242.2	Support Ring SD1800C- II A	1
14	KHT8625-854	GB/T3452.1	O-ring 165×7	1
15	KHT8625-858	GB/T10708.1	Y-ring 125×145×14.5	1
16	KHT8625-859	GB/T15242.2	Support Ring GD 1250B- II A	1
17	KHT8625-860	GB/T10708.3	Dustproof RingFA125×140×9.5	1
18	KHT8625-913	GB/T15242.2	SD 0630- II A	1
19	KHT8625-915	GB/T3452.1	O-ring 32.5×3.55	1
20	KHT8625-916	GB/T10708.1	Y-ring Y80×65×9.5	1
21	KHT8625-922	GB/T3452.1	O-ring 56×3.55	1
22	KHT8625-926	GB/1235	O-ring 24×2.4	1
23	KHT8625-927	GB/T10708.1	Y-ring Y40×50×6.3	1
24	KHT8625-928	GB/T10708.3	Dustproof RingFA40×48×5	1