

MODEL KHT5500
CASING TONG

**MAINTENANCE
AND OPERATION MANUAL**



SAFETY CAUTION

- 8 The operator must read and grasp the manual.
- 9 The operator must wear working clothing, safety shoes, safety helmet, protective glasses, safety gloves, etc.
- 10 Tie tail rope as required in the manual. And the rope should be in the right direction.
- 11 The operation should be carried out on the operation side.
- 12 During making up and breaking out, the safety door should be closed.
- 13 During the operation of power tongs, it is prohibited to stretch hands into the operating parts.
- 14 Other sundries should not be placed in operation area of power tongs.
- 15 During maintenance and replacement of jaw plate, tooth seat, Die, etc., pump or hydraulic source should be stopped or cut off.
- 16 The over-pressure and over-torque operation is prohibited.
- 17 Do not disassemble or add parts arbitrarily.
- 18 Please adopt the original fitting parts made by XIQI-Handa

**If the manual is changed or revised later, we have no obligation to notify any person.
If the pictures vary from the practicality, please accept the practicality.**

Chapter I Summary

KHT5500 hydraulic power tongs is the open power tongs which is applicable to make up or break out 2³/₈"-3¹/₂" drill pipes, 3¹/₂"-4¹/₂" tubing and 4¹/₂"-5¹/₂" casing during oil field workover operation. And three-jaw-plate clamping device is adopted in the master tong and back tongs. The device may ensure minimum string damage. It has high operation efficiency and may reduce working intensity of the workers. It can enhance screwing quality of the string and reduce string accidents caused by improper workover operation.

Characteristics:

16. The tong head is the open structure which is quick and convenient for entering and retreating working position. The integral tong head has good hardness and rigidity;
17. The three-jaw-plate clamping device is adopted in the master tong and back tongs. The device may ensure minimum string damage. The front two jaw plates of the master tong are in the swing structure and the back jaw plate is the roller-climbing structure. The assembly and disassembly is very convenient. The optimum tangent-diameter ratio design ensures reliable clamping and easy slope retreating. The back tong is the three-jaw-plate structure pushed by hydraulic cylinder. The structure is simple and the clamping is reliable;
18. Four-gear rotation is adopted for large speed regulation range. And the rated torque is large;
19. It has the braking mode with braking staple. The braking torque is large. The operation is simple. And it is convenient for repair and replacement;
20. With the open large gear supporting structure, hardness and rigidity of open large gear is enhanced considerably;
21. The shell is made of steel plate with high hardness. The overall hardness is good. Various jaw plates are made with fine casting and forging process. It has beautiful appearance and high hardness;
22. Hydraulic torque indicator is provided. And installation interface of turning torque instrument is provided for computerized management.

Chapter II Technical parameters

16. Applicable range	Master tong: 2 ³ / ₈ "--5 ¹ / ₂ "; Back tong: 2 ³ / ₈ "--6 ¹ / ₂ "	
17. Opening size (master tong)	5 7/8" (150 mm)	
18. Tong head speed: (@40GPM / 150 LPM)	High gear	78 RPM
	Second high gear	33 RPM
	Second low gear	22 RPM
	Low gear	9.5 RPM
19. Torque	High gear	2500 ft.lb/3400 N·m

(@2000PSI / 14 MPa)	Second high gear	5900 ft.lb/8000 N·m
	Second low gear	8800 ft.lb/12000 N·m
	Low gear	20000 ft.lb/27000 N·m
5. Overall dimensions (L×W×H) 48"×33.9"×67.3" / 1220×860×1708 mm		
1. Weight: Master tong: 1230 lb		
Composite tong: 2100 lb		
7. Specifications of jaw plates: 5.5"(139.7mm), 5"(127mm), 4.5"(114.3mm), 3.5"(88.9mm), 2.88"(73mm), 2.38"(60.3mm) and 6.5"(165.1mm)		

Chapter III Installation of Power Tongs

- Hang the tongs
- Fix the single pulley (with the load of 5 tons) on the bottom girder of the crown.
- Put the Slip wire rope (which has a diameter of not less than 1/2") through the pulley. One end of wire rope fastened on the bottom girder, and other end fastened on the lift bucket (master tong can choose to use spring lift bucket、combined tong can choose to use hydraulic lift bucket) ,The height of power tongs should be equal to the average height of connectors for tripping string.
- Leveling Power Tongs

It is necessary to level the tongs after Hang the tongs. Otherwise, it will lead to tong tooth slipping.

Front-rear leveling: it is adjusted through the left and right two horizontal bolts at the connection position between lifting bracket and tong body of the power tongs.

Transverse leveling: it is adjusted through leveling bolts on the upper part of lifting bracket. And it may be adjusted through turning the bolts.

III. Tie the back guy

Tail rope diameter should be no less than 5/8". One end of tail rope is fixed on tong tail seat. And another end is fixed on drilling platform or the derrick. Note: when tail rope is tightened, it should be in the same level with power tongs and perpendicular to median line of tong body.

I. Refueling Torque Cylinder

Master tong: when stretched length of piston rod of tension cylinder reaches 1 1/8" (28 mm), it is necessary to add oil.

Composite tong: when the piston of tension cylinder is retreated to the position which is 1/4" (6.35 mm) away from cylinder end, it is necessary to add oil.

When it is necessary to add oil, remove quick connector from torque cylinder and insert it into the quick connector which is on the oil filled equipment (Purchase Code: KHT5500-190) . After oil filling, connect it with quick connector which is on the torque meter. Then release plug on torque cylinder until the pressure on torque meter turns to zero.

Note: Torque testing system of master tong and Torque testing assembly can be selected according to user needs.

II. Pipe Connection

High-pressure oil feeding pipe: NPT1" port is connected with high-pressure hose from hydraulic station;

Low-pressure oil return pipe: NPT1 1/4" port is connected with low-pressure hose from hydraulic station;

Note :We will supply High-pressure oil feeding pipe and Low-pressure oil return pipe for the users according to their requirement on the length connection thread.

III. Soft shaft door control device

Soft shaft door control device can be used for XQs; ZQs and TQs, protecting the power tong quick-in-time and keep the operator in safe situation.

Soft shaft door control device consists of reversing valve, push-pull shaft and safety door. We fix flexible shaft reversing valve at the inlet of the manual reversing valve and we can make flexible shaft and safety door become linked by pushing or pulling it.

Note: 1, The power tongs rated system pressure is 16MPa, overpressure use is not allowed, it will cause damage to the power tongs;

2, Before using, the safety door must be closed, otherwise the power tong will fail to work.

3, This device can be selected according to the needs of users.

Chapter IV Operation Regulation

I. Operator's Requirements

1. Learn overall structure and performance of power tongs basically;
2. Be familiar with the operation of hydraulic reversing handle on power tongs:

When manual reversing valve of control master tong is pushed, large gear on master tong turns in the making-up tong direction; when manual reversing valve of control master tong is pulled, large gear on master tong turns in the braking-out tong direction;

When manual reversing valve of control back tong is pushed, back tong is clamped; when manual reversing valve of control back tong is pulled, back tong is released.

3. Be familiar with the operation of shifting handle (various gears of shifting handle are shown in Figure 1):

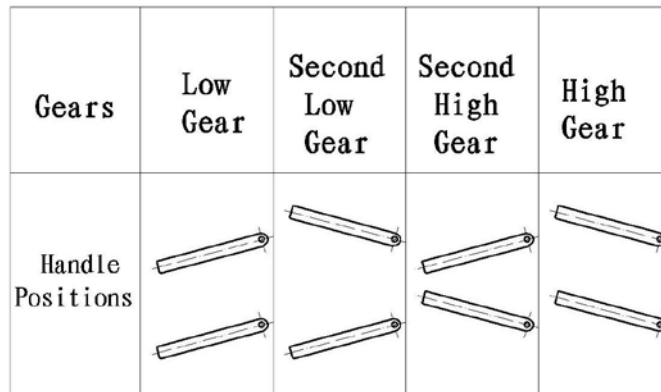

Fig. 1

4. Adjustment of safety door clearance

The clearance between safety door buckle and latch seat on the shell may be regulated through adjusting turning angle of eccentric shaft for minimum clearance for normal opening of safety door.

5. Learn operation sequence and safety requirements;
6. Be familiar with the instrument operation.

II. Operation of Power Tongs

1. Learn specifications of jaw plates and Die: jaw plates of master tong has 6 specifications and jaw plates of back tong has 7 specifications. Each specification has three jaw plates including 2 front jaw plates and one rear jaw plate (as shown in Figure 2 and Figure 3). The front two jaw plates are the same and may be installed on the left and right. During installing jaw plate, it is necessary to check whether Die is worn or clean. It is necessary to tighten fixation bolts of Die.

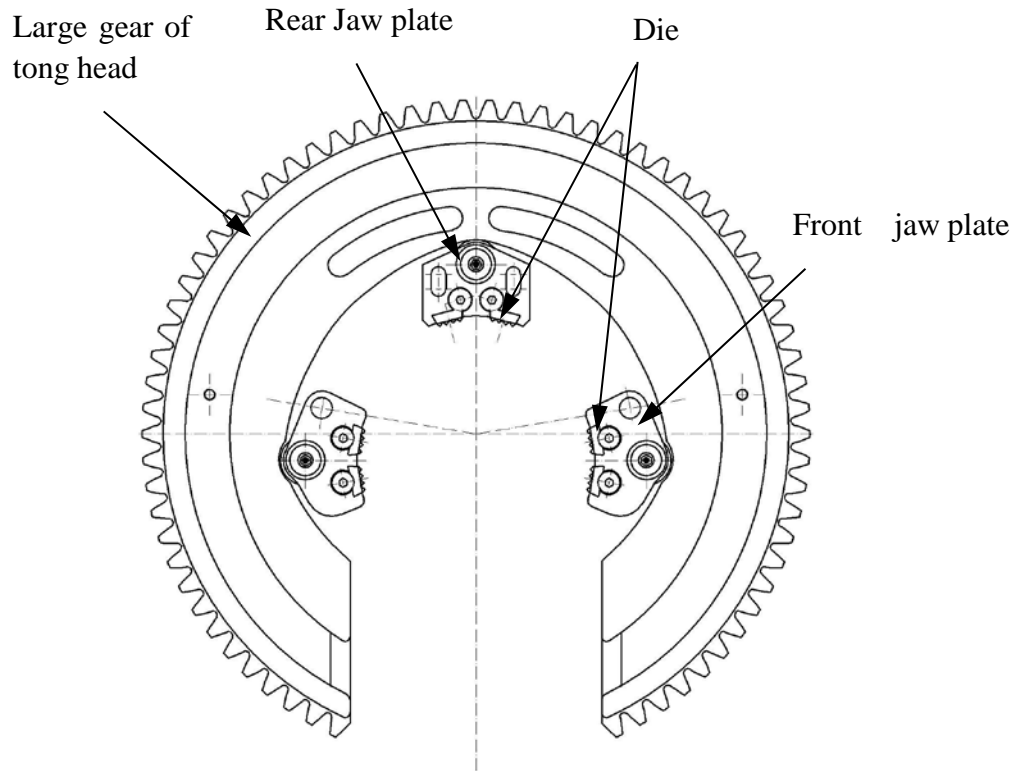

Fig. 2 Tong head and jaw plate of the master tong

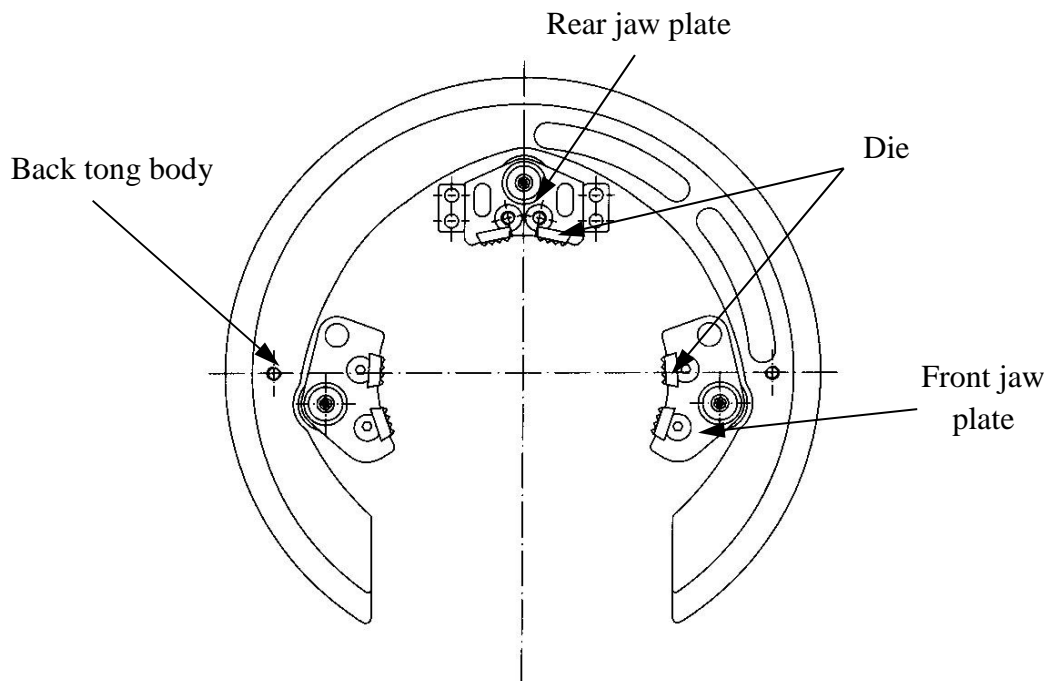

Fig.3 Back tong body and jaw plate

2. Install jaw plate and Die with corresponding size for the string.
3. Put shifting handle of the upper and lower shifting device on the neutral position;
4. Start hydraulic power station;

5. When hydraulic reversing handle is pushed or pulled, rotation noise of hydraulic motor should be heard and open gear of tong head should not rotate;
6. When shifting handle is put on any gear and hydraulic reversing handle is pushed or pulled, positive or negative rotation of open gear of tong head should be flexible;

Note: shifting should be carried out when hydraulic motor stops the rotation.

III. Working Process

1. Align the opening of large gear of tong head with the opening of jaw plate bracket.
2. Insert reversing pin into making-up and breaking-out hole according to the operation requirements and adjust the tight degree of braking staple.
3. Align the opening of large gear of tong head with the shell opening.
4. Pull out safety door, push power tongs toward the string to allow the string to be on the central position of tong head and close safety door.
5. Making-up operation regulation
 - a. Put shifting handle on high gear and push reversing valve handle of back tong to allow back tong to clamp the string. Release reversing valve handle of back tong to allow reversing valve handle to return median position. Then push reversing valve handle of master tong to allow jaw plate to clamp the string. Large gear of tong head drives the string to rotate in the making-up direction. At the same time, observe the torque: if the readings do not reach the required value, it is necessary to shift the second high gear, the second low gear and low gear. Then push reversing valve handle of the master tong to allow jaw plate to clamp the string. And large gear of tong head drives the string to rotate. At the same time, observe the torque meter. When the readings reach the required value, release reversing valve handle of the master tong to allow reversing valve handle to return the median position.
 - b. Pull reversing valve handle of back tong to allow back tong to release the string; then pull reversing valve handle of the master tong. According the familiar degree and open gear position, the operator should select the low gear. The jaw plate will release the string. Large gear of tong head rotates in breaking-out direction until it is aligned with the shell opening. Release manual reversing valve handle to allow reversing valve handle to return the median position.
 - c. Open the safety door and remove power tongs from the string. Then one making-up operation is completed.
6. Breaking-out operation regulation
 - a. Put shifting handle on the second high gear, the second low gear and low gear and push reversing valve handle of back tong to allow back tong to clamp the string. Release reversing valve handle of back tong to allow reversing valve handle to return median position. Then pull reversing valve handle of master tong to allow jaw plate to clamp the string. Large gear of tong head drives the string to rotate in the breaking-out direction.

- b. When the string rotates in certain degree and high gear may rotate, put shifting handle on high gear. Pull reversing valve handle of the master tong to allow jaw plate to clamp the string. And large gear of tong head drives the string to rotate in the breaking-out direction quickly.
- c. At the end of breaking-out the tong, pull reversing valve handle of back tong to allow back tong to release the string; then push reversing valve handle of the master tong. According the familiar degree and opening position, the operator should select the low gear. The jaw plate will release the string. Large gear of tong head rotates in making-up direction until it is aligned with the shell opening. Release reversing valve handle of the master tong to allow reversing valve handle to return the median position.
- d. Open safety door and remove power tongs from the string. Then one breaking-out operation is completed.

IV. Cautions

1. During the disassembly and assembly of jaw plates, you must shut down the hydraulic power unit to prevent accidents.
2. Ensure that lifting suspension of power tongs was is leveled;
3. Ensure that all the pipelines are connected properly;
4. During assembling jaw plates, jaw plates with corresponding pipe diameter should be adopted.
5. During shifting, hydraulic motor should be stopped.
6. Before safety door is closed, manual reversing valve should not be operated to avoid hands or other parts of the operator to enter the opening to lead to damage.
7. Check the clearance between safety door and the shell at any time for normal opening/closing safety door. If the clearance is too large, power tongs will be damaged.
8. Check the safety reliability of lifting rope and tail rope at any time.
9. When the pressure of overflow valve of hydraulic power unit is adjusted to 2000PSI (14MPa), pressure adjustment handle should be locked firmly.
10. When the tongs is operating under the torque higher than 15000ft.lb, it is necessary to ensure that two intermediate wheels are engaged in large open gear.

Chapter V Care and Maintenance

- IV. Establish post responsibility system.
- V. Apply lubricant on grease fitting and skidding surface before each operation.
- VI. Before the operation, the tongs should be rotated for one time as required in Article 2 in Chapter IV.
- VII. After the operation, it is necessary to clean the tongs and apply butter on the rotating position of tong head to prevent rust.

VIII. When the tongs is not used, it should be stored in a place far away from the drilling rig floor. The exposed part of the tong head should be coated with butter and the storage place should be clean and dry.

IX. In the demobilization, close the oil ports to prevent the foreign objects to enter the pipelines.

X. After the completion of running the strings in 10 wells, overhaul is required for the power tongs.

Chapter VI Troubleshooting

Failure phenomena	Causes	Troubleshooting
Tong head does not rotate.	1 Hydraulic power unit supplies no pressure. Hydraulic manual reversing valve is damaged. 2 Shifting device fails.	1 Check hydraulic power station. · Replace the valve. 2 It requires repair. ·
Tong head speed is not	1 Pressure or displacement of hydraulic power unit is not enough. · Loss of hydraulic motor or 2 hydraulic reversing valve is large.	1 Check hydraulic power · Replace the motor or 2 manual reversing valve. ·
Tong head slips	1 Jaw plate size is not suitable for the string size. · Power tongs is not 2 leveled. Tong tooth is · worn. 3 Tong tooth groove is filled with · filth. Braking staple is too loose or 4 worn. Jaw plate roller does not	1 Replace suitable jaw plate. · Adjust levels of power tongs. 2 Replace new tong tooth. · Remove filth with wire 3 brush. Adjust braking staple · or replace new braking 4 staple. · 5 Repair and refuel jaw plate
Torque does not reach the rated value.	1 The pressure of hydraulic power unit is too low or pump displacement is not enough. Hydraulic motor or reversing valve fails. Oil in hydraulic cylinder is not enough or sealing ring is worn. 2 · 3 Torque meter fails. ·	1 Treat it according to the manual of hydraulic power unit. · Repair or replace it. 2 Add oil or replace sealing ring · 3 Repair or replace torque meter.
When motor rotating, tong head does not rotate or rotate; under stops.	1 Shifting device fails. · Loss of hydraulic motor or 2 manual reversing valve is large. · Gearbox gear is damaged or worn badly.	1 Repair or replace it. · 2 Repair or replace the motor or reversing valve. · Check or repair the gearbox.

Chapter VII List of Parts

6. General assembly (Fig 4, Table 1)
7. Assembly of master tong (Fig 5, Table 2)
8. Assembly of tong head (Fig 6, Table 3)
9. Shell and Accessories I (Fig 7, Table 4)
10. Shell and Accessories II (Fig8, Table 5)
11. Drive gear of master tong (Fig9, Table 6)
12. Assembly of safety door (Fig 10, Table 7)
13. Gear engagement Assembly (Fig11, Table8)
14. Hydraulic pipeline (Fig12, Table 9)
15. Quintuple valve (Fig 13, Table 10)
16. Quick coupling (2 1/8-12UN) (Fig 14, Table 11)
17. Quick coupling (1 7/8-12UN) (Fig 15, Table 12)
18. Bend sub (1 5/16-12UN) (Fig 16, Table 13)
19. Bend sub (9/16-18UNF) (Fig 17, Table 14)
15. Bend sub (NPT1 1/4-1 5/8-12UN) (Fig 18, Table 15)
1. Bend sub (NPT1-1 5/16-12UN) (Fig 19, Table 16)
2. Assembly of suspension rod (Fig 20, Table 17)
3. Assembly of back tong (Fig 21, Table 18)
4. Backup Tong Transmission assembly (Fig 22, Table 19)
5. Clamping cylinder assembly (Fig23, Table 20)
6. Backup Tong Safety doorassembly (Fig24, Table21)
7. Assembly of suspension chain (Fig 25, Table 22)
8. Assembly of front guide rod (Fig26, Table 23)
9. Hydraulic spring tube assembly(Fig 27, Table 24)
10. Torque testing assembly (Fig28, Table25)
11. Torque testing system of mastertong (Fig29, Table26)
12. Oil filled equipment (Fig30, Table27)
13. Soft shaft door control device (Fig31, Table28)
14. Spring lift bucket assembly (Fig32, Table29)

- General assembly (Fig 4, Table 1)

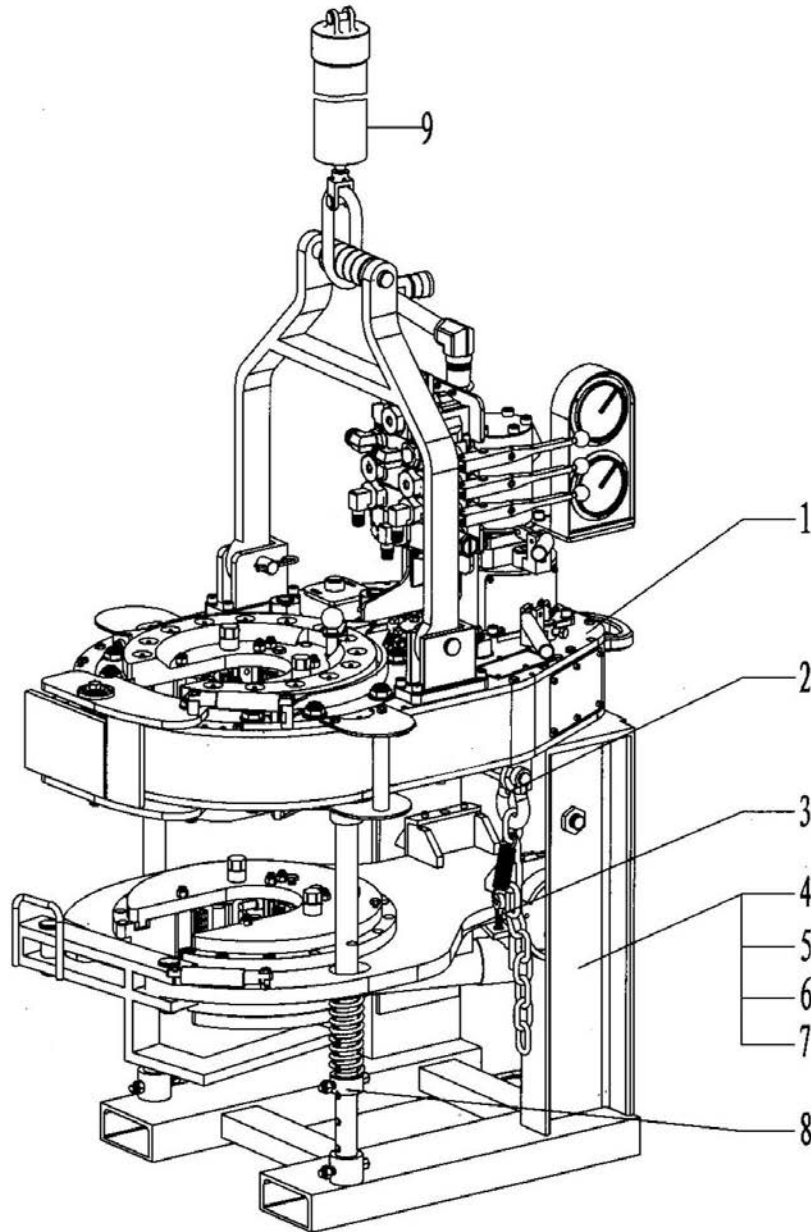

Fig -4

Table 1 List of General assembly

N	Purchase Code	Drawing No.	Names and specifications of parts	Quanti
1	KHT5500-01	KHT5500.1	Master tong	1
2	KHT5500-02	KHT5500.3	Suspension chain assembly	2
3	KHT5500-03(2)	KHT5500.2(2)	Back tong	1
4	KHT5500-04	KHT5500.4	Rear support	1
5	KHT5500-05		Hexagon socket cap head screws 1/2"×1	6
6	KHT5500-06		Hexagon socket cap head screws 1/2"×2	2
7	KHT5500-07		Spring washer 1/2"	8
8	KHT5500-08	KHT5500.5	Front guide assembly	2
9	KHT5500-9A	KHT9625.1.17	Hydraulic spring tube assembly	1
	KHT5500-9B	KHT9625.1.17 (2)	Hydraulic spring tube assembly(2)	1

- Assembly of master tong (Fig5, Table 2)

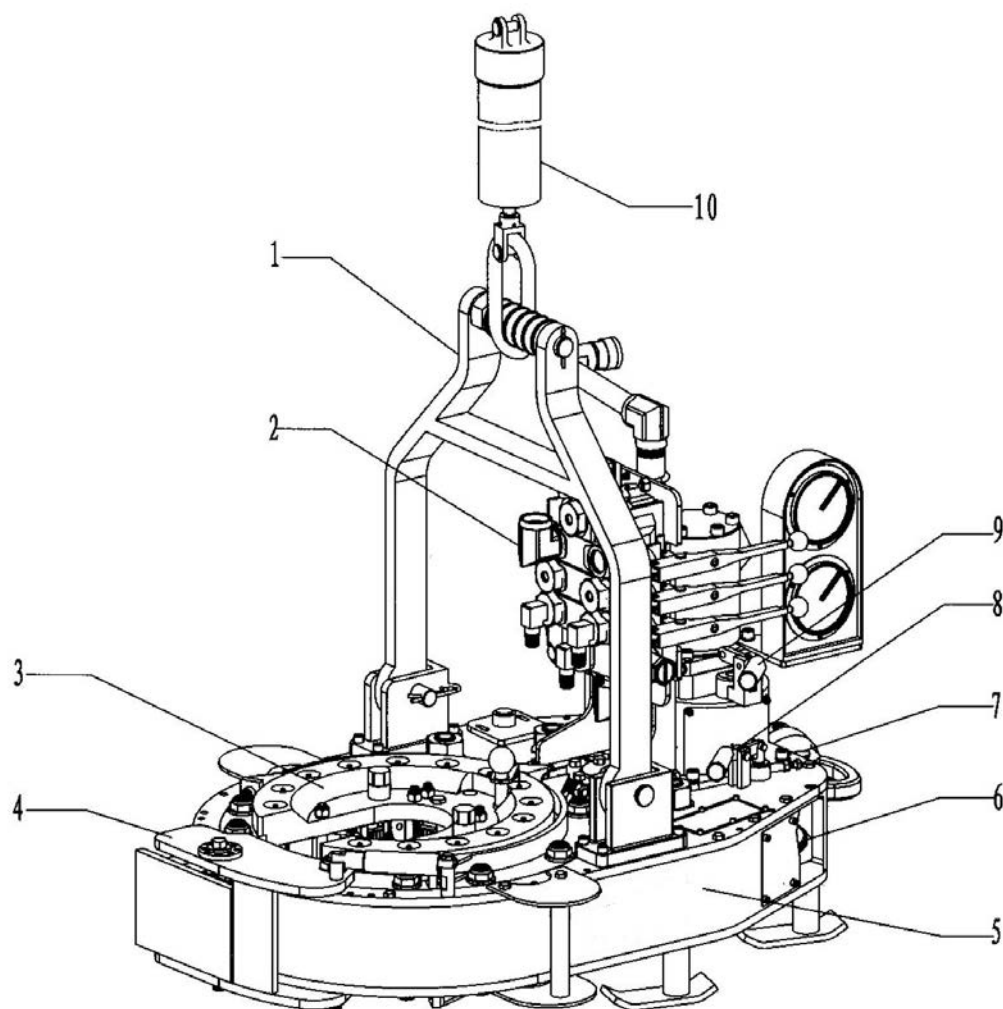

Table 2 List of Master tong

N	Purchase	Drawing No.	Names and specifications of parts	Quanti
1	KHT5500-09	KHT5500.1.12	Suspension rod assembly	1
2	KHT5500-10	KHT5500.1.8	Hydraulic valve and hydraulic pipeline	1
3	KHT5500-11	KHT5500.1.1	Tong head assembly	1
4	KHT5500-12	KHT5500.1.10	Safety door assembly	1
5	KHT5500-13		Shell and Accessories I	1
6	KHT5500-14		Drive gear of master tong	1
7	KHT5500-15	KHT5500.1.14	Torque testing assembly of master	1
8	KHT5500-16		Shell and Accessories II	1
9	KHT5500-17	KHT9625.1.14	Gear engagement assembly (upper)	1
1	KHT5500-9C	TQ340/35Y.1.13 (2)	Spring lift bucket assembly	1

- Assembly of tong head (**Fig 6, Table 3**)

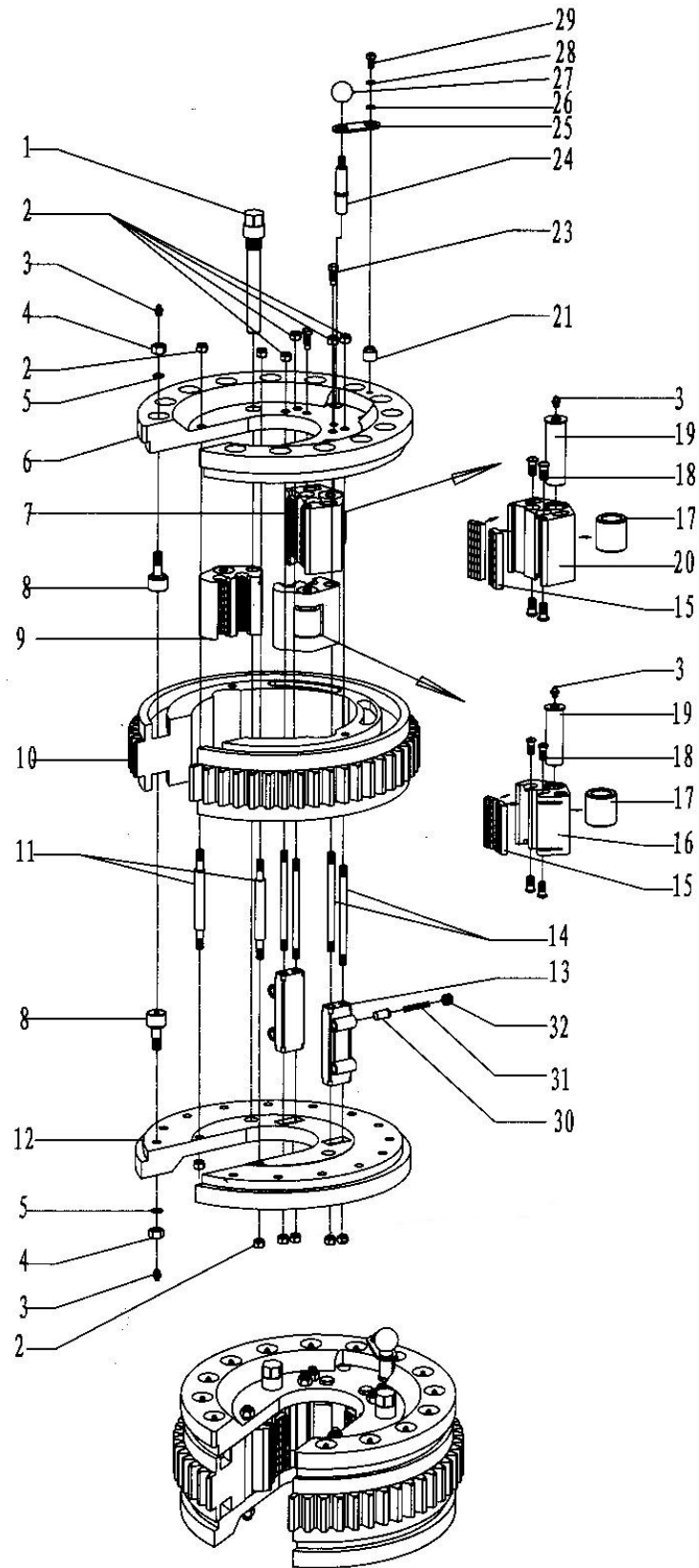

Fig. 6

Table 3 List of Tong head

No.	Purchase Code	Drawing No.	Names and specifications of parts	Quantit
1	KHT5500-18	KHT5500.1.1-4	Jaw plate bolt	2
2	KHT5500-19		Hexagon check nut 1/2"	12
3	KHT5500-20	GB/T1152	Oil cup M6×1	31
4	KHT5500-21		Hexagon nut 9/16"-12UNC	28
5	KHT5500-22		Spring washer 9/16"	28
6	KHT5500-23	KHT5500.1.1-1	Upper jaw plate bracket	1
7	KHT5500-24 (1	KHT5500.1.1.2 (1)	Rear jaw plate assembly (5 1/2)	1
	KHT5500-24 (2	KHT5500.1.1.2 (2)	Rear jaw plate assembly (5)	1
	KHT5500-24 (3	KHT5500.1.1.2 (3)	Rear jaw plate assembly (4 1/2)	1
	KHT5500-24 (4	KHT5500.1.1.2 (4)	Rear jaw plate assembly (3 1/2)	1
	KHT5500-24 (5	KHT5500.1.1.2 (5)	Rear jaw plate assembly (2 7/8)	1
	KHT5500-24 (6	KHT5500.1.1.2 (6)	Rear jaw plate assembly (2 3/8)	1
8	KHT5500-25	KHT5500.1.1.3.1	Alignment roller	28
9	KHT5500-26 (1	KHT5500.1.1.1 (1)	Front jaw plate assembly (5 1/2)	each 2
	KHT5500-26 (2	KHT5500.1.1.1 (2)	Front jaw plate assembly (5)	each 2
	KHT5500-26 (3	KHT5500.1.1.1 (3)	Front jaw plate assembly (4 1/2)	each 2
	KHT5500-26 (4	KHT5500.1.1.1 (4)	Front jaw plate assembly (3 1/2)	each 2
	KHT5500-26 (5	KHT5500.1.1.1 (5)	Front jaw plate assembly (2 7/8)	each 2
	KHT5500-26 (6	KHT5500.1.1.1 (6)	Front jaw plate assembly (2 3/8)	each2
10	KHT5500-27	KHT5500.1.1-2	Open gear	1
11	KHT5500-28	KHT5500.1.1-10	Supporting bolt	2
12	KHT5500-29	KHT5500.1.1-3	Lower jaw plate bracket	1
13	KHT5500-30	KHT5500.1.1-9B	Limiting Plate	2
14	KHT5500-31	KHT5500.1.1-5	Double threaded screw	4
15	KHT5500-32 (1	KHT9625.1.1.1-2 (1)	Die 1 (7/16")	each 6
	KHT5500-32 (2	KHT9625.1.1.1-2 (2)	Die 2 (1/2")	each 6
	KHT5500-32 (3	KHT9625.1.1.1-2 (3)	Die 3 (9/16")	each 6
	KHT5500-34 (4	KHT9625.1.1.1-2 (4)	Die 4 (5/8")	each 6
	KHT5500-32 (5	KHT9625.1.1.1-2 (5)	Die 5 (11/16")	each 6
	KHT5500-32 (6	KHT9625.1.1.1-2 (6)	Die 6 (3/4")	each 6
	KHT5500-32 (7	KHT9625.1.1.1-2 (7)	Die 7 (13/16")	each 6
	KHT5500-32 (8	KHT9625.1.1.1-2 (8)	Die 8 (7/8")	each 6
	KHT5500-32 (9	KHT9625.1.1.1-2 (9)	Die 9 (15/16")	each 6
	KHT5500-32 (10	KHT9625.1.1.1-2	Die 10 (1")	each 6
	KHT5500-32 (11	KHT9625.1.1.1-2	Die 11 (1 1/16")	each 6
16	KHT5500-43	KHT5500.1.1.1-1 (1)	Front Jaw Plate 1 (5 1/2")	each 2
	KHT5500-44	KHT5500.1.1.1-1 (2)	Front Jaw Plate 2 (5")	each 2
	KHT5500-45	KHT5500.1.1.1-1 (3)	Front Jaw Plate 3 (4 1/2")	each 2
	KHT5500-46	KHT5500.1.1.1-1 (4)	Front Jaw Plate 4 (3 1/2")	each 2
	KHT5500-47	KHT5500.1.1.1-1 (5)	Front Jaw Plate 5 (2 7/8")	each 2

	KHT5500-48	KHT5500.1.1.1-1 (6)	Front Jaw Plate 6 (2 3/8")	each 2
17	KHT5500-49	KHT9625.1.1.1-4	Roller	3
18	KHT5500-50		Hexagon socket head cap screw	12
19	KHT5500-51	KHT9625.1.1.1-3	Roller shaft	3
20	KHT5500-52	KHT5500.1.1.1-1 (1	Rear Jaw Plate 1 (5 1/2")	each
	KHT5500-53	KHT5500.1.1.1-1 (2	Rear Jaw Plate 2 (5")	each
	KHT5500-54	KHT5500.1.1.1-1 (3	Rear Jaw Plate 3 (4 1/2")	each
	KHT5500-55	KHT5500.1.1.1-1 (4	Rear Jaw Plate 4 (3 1/2")	each
	KHT5500-56	KHT5500.1.1.1-1 (5	Rear Jaw Plate 5 (2 7/8")	each
	KHT5500-57	KHT5500.1.1.1-1 (6	Rear Jaw Plate 6 (2 3/8")	each
21	KHT5500-58	KHT5500.1.1-7	Bushings	1
23	KHT5500-59	KHT9625.1.1-10	Limiting bolt	2
24	KHT5500-60	TQ340/35Y.1.5.2-02	Pin	1
25	KHT5500-61	KHT5500.1.1-6	Connection plate	1
26	KHT5500-62	GB/T95	Plain washer 10	1
27	KHT5500-65	TQ340/35Y.1.5.2-05	Ball knob	1
28	KHT5500-63		Spring washer 3/8"	1
29	KHT5500-64		Hexagon bolt 3/8"×1 3/4"	1
30	KHT5500-380	KHT5500.1.1-11B	Spring pocket	4
31	KHT5500-381	KHT5500.1.1-8B	Spring	4
32	KHT5500-382	KHT5500.1.1-13B	Leveling screw	4

- Shell and accessories I (Fig 7, Table 4)

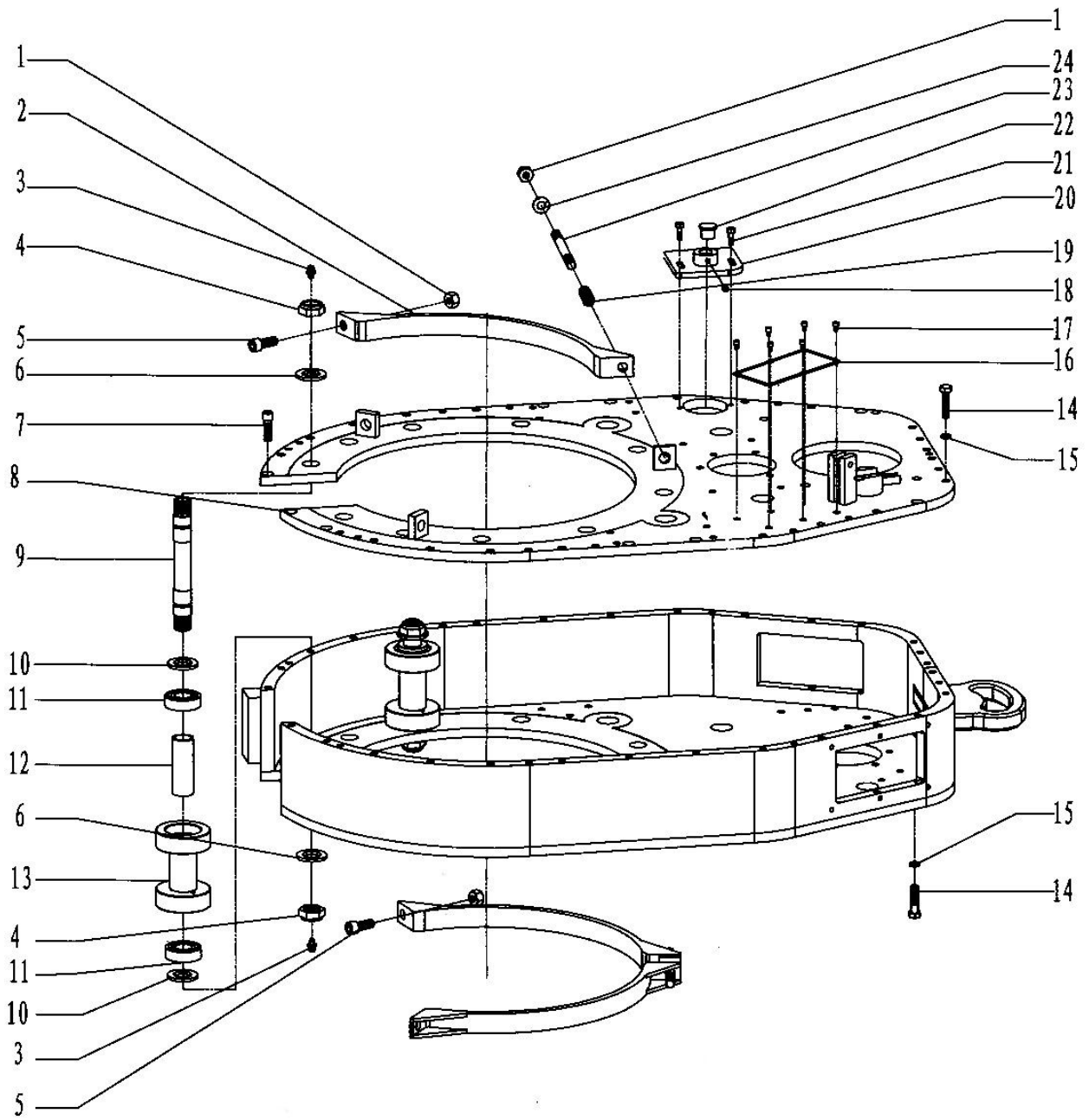

Fig.7

Table 4 List of Shell and accessories I

N	Purchase	Drawing No.	Names and specifications of parts	Quanti
1	KHT5500-19		Hexagon check nut 1/2"	8
2	KHT5500-66	KHT5500.1.11.1	Braking staple	4
3	KHT5500-20	GB1152	Oil cup M6	18
4	KHT5500-67	KHT5500.1.9.1	Check nut 15/16"-1 2UN	18
5	KHT5500-05		Hexagon socket cap head screws 1/2"×1 1/2"	4
6	KHT5500-68	GB/T95	Washer 24	18
7	KHT5500-69		Hexagon socket cap head screws 3/8"×1 "	18
8	KHT5500-70	KHT9625.1.2	Shell	1
9	KHT5500-71	KHT5500.1.9-4	Righting shaft	9
1	KHT5500-72	KHT5500.1.9-1	Washer	18
1	KHT5500-73	GB/T276	Aligning ball shaft 1205	18
1	KHT5500-74	KHT5500.1.9-2	Lining	9
1	KHT5500-75	KHT5500.1.9-3	Alignment Idler wheel	9
1	KHT5500-76		Hexagon bolt 3/8"×1 1/2"	38
1	KHT5500-63		Spring washer 3/8"	58
1	KHT5500-77	KHT5500.1.2-7	Nameplate	1
1	KHT5500-78		Hexagon socket cap head screws 1/4"×5/16"	6
1	KHT5500-79		Locking bolt	1
1	KHT5500-80	ZQ25.1.8-8	Braking spring	4
2	KHT5500-81	KJD9625.16	Measuring speed gear seat	1
2	KHT5500-82		Hexagon socket cap head screws 1/4"×3/4"	50
2	KHT5500-83	KJD9625.16-2	Measuring speed gear shaft	1
2	KHT5500-84	KHT5500.1.11-1	Double threaded stud	1
2	KHT5500-85	GB/T95	Plain washer 12	2

- Shell and accessories II (Fig 8, Table 5)

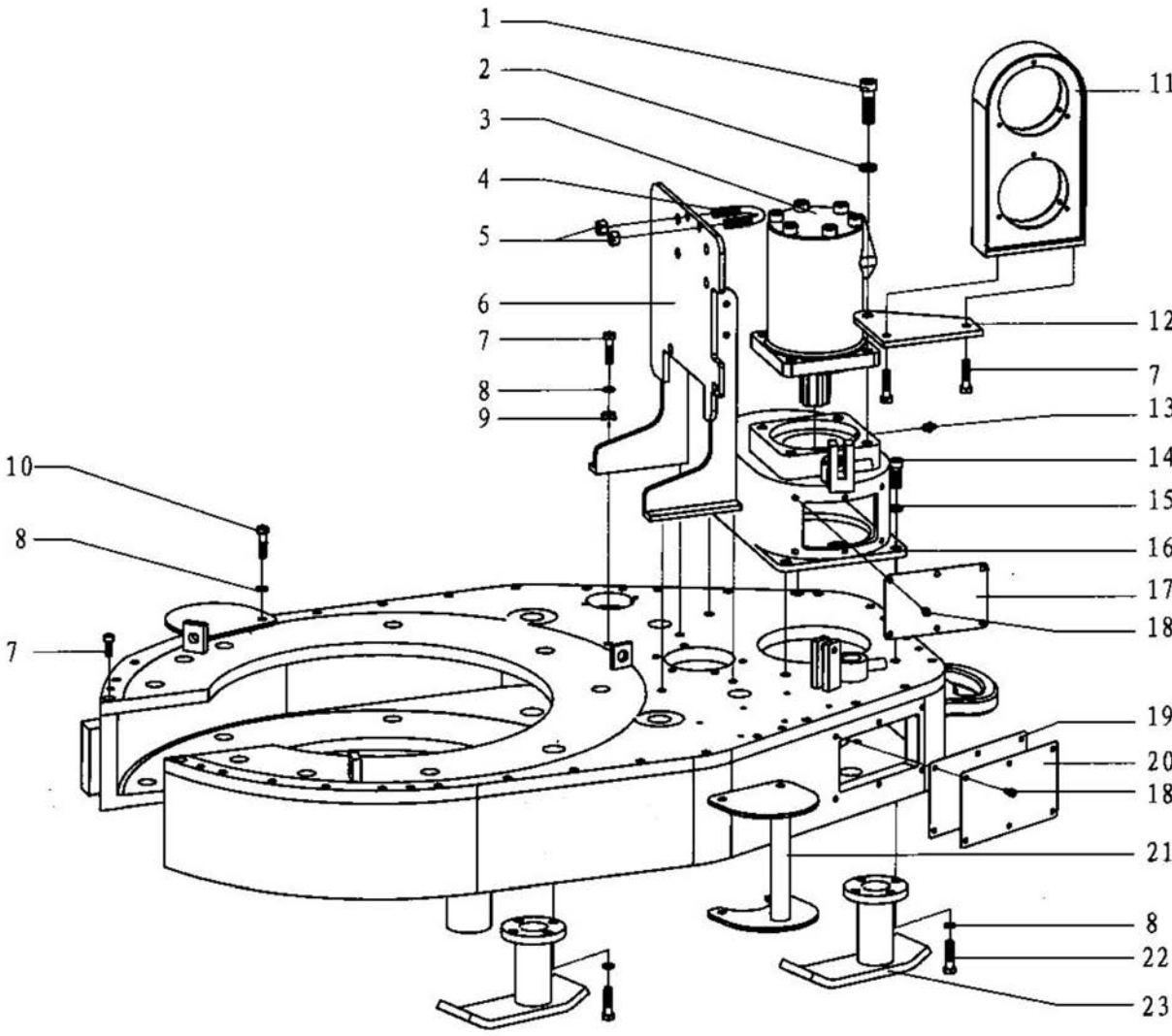

Fig. 8

Table 5 List of Shell and accessories II

N	Purchase	Drawing No.	Names and specifications of parts	Quanti
1	KHT5500-		Hexagon socket cap head screws 5/8"×2"	4
2	KHT5500-86		Spring washer 5/8"	4
3	KHT5500-87		6K-625 orbit hydraulic motor (tubular connection)	1
	KHT5500-		6K-625 orbit hydraulic motor (plate connection)	1
4	KHT5500-88	KJD9625-5	U-bolt	1
5	KHT5500-89		Check nut 3/8"	2
6	KHT5500-90	KHT5500.1.8.1	Valve connection assembly	1
7	KHT5500-69		Hexagon socket cap head screws 3/8"×1"	24
8	KHT5500-63		Spring washer 3/8"	78
9	KHT5500-92	KHT5500.1.8-1	Stair seat	4
1	KHT5500-76		Hexagon bolt 3/8"×1 1/2"	38
1	KHT5500-93	KJD9625.11 (2	Pressure gauge seat	1
1	KHT5500-94	KJD9625-4	Fixation plate of gauge seat	1
1	KHT5500-95		Forced filling oil cup NPT1/8"	1
1	KHT5500-96		Hexagon socket cap head screws 1/2"×1 1/4"	4
1	KHT5500-07		Spring washer 1/2"	4
1	KHT5500-97	KHT5500.1.7.1	Small cabinet	1
1	KHT5500-98	KHT9625.1.7-1	Orifice plate	1
1	KHT5500-78		Hexagon socket cap head screws 1/4"×5/16"	12
1	KHT5500-99	KHT9625.1.2-7	Orifice plate	1
2	KHT5500-	KHT9625.1.2-	Gear nameplate	1
2	KHT5500-	KHT5500.1.2.1	Handler	2
2	KHT5500-		Hexagon bolt 3/8"×1 1/8"	16
2	KHT5500-	TQ245.7	Support leg	4

- Drive gear of master tong (Fig 9, Table 6)

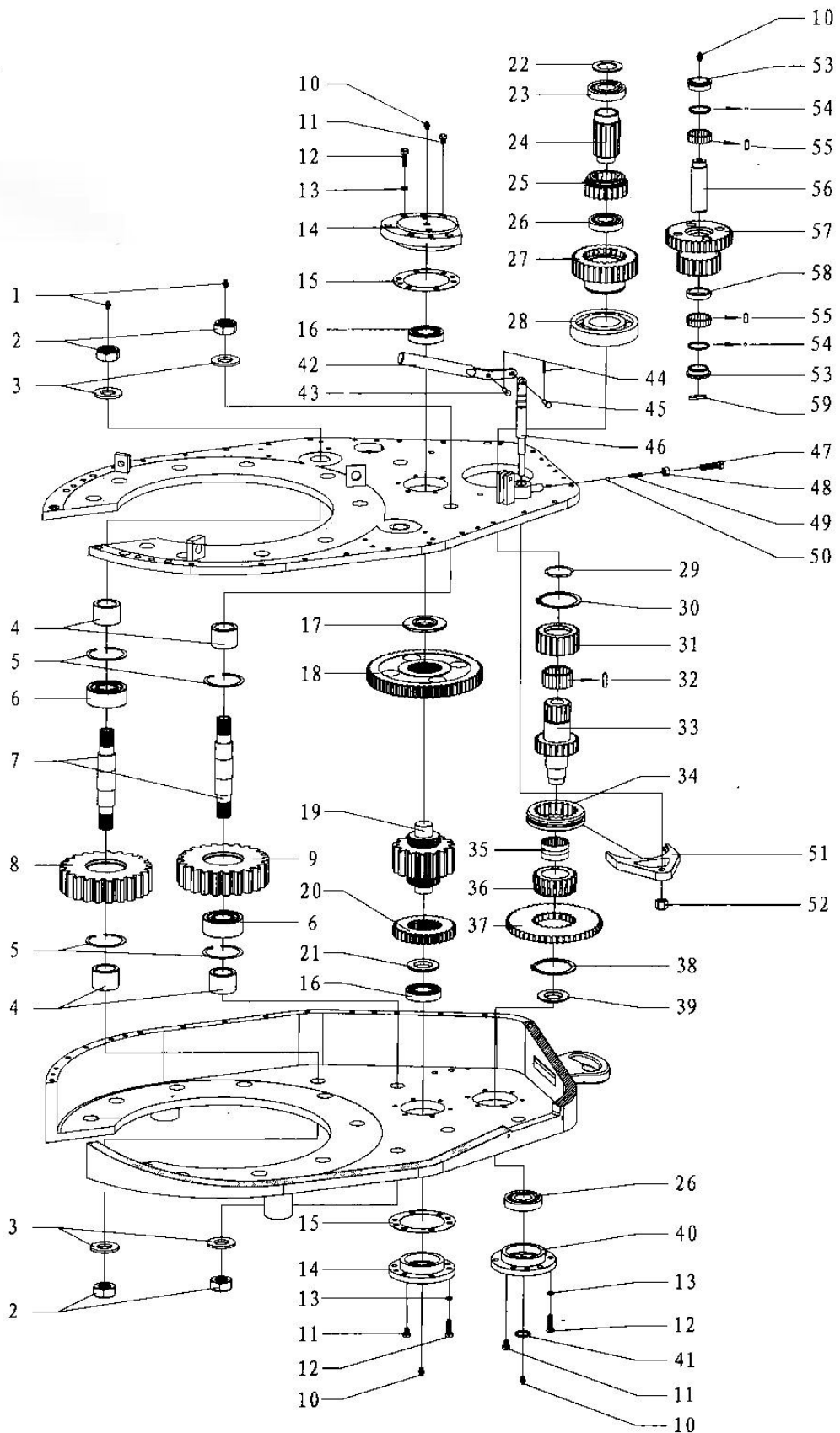

Fig. 9

Table 6 List of Drive gear of master tong

No	Purchase	Drawing No.	Names and specifications of parts	Quanti
1	KHT5500-20	GB/T1152	Oil cup M6×1	4
2	KHT5500-104		Hexagon check nut 1 1/4-7UNC	8
3	KHT5500-105	KHT9625.1.3-1	Washer	8
4	KHT5500-106	KHT9625.1.3-3	Lining ring	8
5	KHT5500-107	GB/T893.1	Elastic retainer ring for hole 90	8
6	KHT5500-108	GB/T296	Double row angular contact ball bearing	4
7	KHT5500-109	KHT5500.1.3-1	Small intermediate wheel shaft	4
8	KHT5500-110	KHT5500.1.3-2	Small intermediate wheel	2
9	KHT5500-111	KHT5500.1.4-1	Large intermediate wheel	2
10	KHT5500-95		Forced filling oil cup NPT1/8"	4
11	KHT5500-167		Hexagon bolt 3/8"×1/2"	6
12	KHT5500-112		Hexagon bolt 3/8"×1 1/4"	17
13	KHT5500-63		Spring washer 3/8"	17
14	KHT5500-113	KHT5500.1.5-1	Upper bearing cover	2
15	KHT5500-114	KHT9625.1.5-2	Spacer shim	2
16	KHT5500-115	GB/T283	Cylindrical roller bearing NJ208E	2
17	KHT5500-116	KHT9625.1.5-7	Washer	1
18	KHT5500-117	KHT5500.1.5-2	Large gear	1
19	KHT5500-118	KHT5500.1.5-3	Gear shaft	1
20	KHT5500-119	KHT5500.1.5-4	Small gear	1
21	KHT5500-120	KHT5500.1.5-6	Bearing strip	1
22	KHT5500-121	XYQ12.Z-23	Gasket	1
23	KHT5500-122	GB/T276	Ball bearing 111	1
24	KHT5500-123	KHT9625.1.6-1	Spline shaft	1
25	KHT5500-124	KHT9625.1.6-2	Shift engagement gear (upper)	1
26	KHT5500-125	GB/T276	Ball bearing 208	2
27	KHT5500-126	KHT9625.1.6-3	Main shaft gear	1
28	KHT5500-127	GB/T276	Ball bearing 218	1
29	KHT5500-128	GB/T895.2	Wire retainer ring for shaft 60	1
30	KHT5500-129	GB/T893.1	Flexible retainer ring for shaft 90	1
31	KHT5500-130	KHT9625.1.6-4	Clutch gear (upper)	1
32	KHT5500-131	GB/T309	Rolling needle φ5×29.8	41
33	KHT5500-132	KHT9625.1.6-5	Main shaft	1
34	KHT5500-133	KHT9625.1.6-6	Inner geared sleeve	1
35	KHT5500-134	GB/T5801	Single row needle roller bearing without inner ring NK50/35	1
36	KHT5500-135	KHT9625.1.6-7	Small clutch gear	1

No	Purchase	Drawing No.	Names and specifications of parts	Quanti
37	KHT5500-	KHT5500.1.6-1	Large clutch gear	1
38	KHT5500-	GB/T893.1	Flexible retainer ring for shaft 95	1
39	KHT5500-	KHT9625.1.6-9	Bearing strip	1
40	KHT5500-	KHT5500.1.6-2	Bearing cover	1
41	KHT5500-	GB/T3452	O-ring 35.5×3.55	1
42	KHT5500-	TQ245.8-1	Operation rod	1
43	KHT5500-	GB882-86	Pin roll B8×35	1
44	KHT5500-	GB91-86	split pin 2.5×12	2
45	KHT5500-	GB882-86	Pin roll B8×28	1
46	KHT5500-	KHT9625.1.13-	Declutch shift shaft (Lower)	1
47	KHT5500-		Hexagon bolt 1/2"×1 3/4"	1
48	KHT5500-		Hexagon nut 1/2"	1
49	KHT5500-	TQ245.8-2	Positioning spring	1
50	KHT5500-		Steel ball 5/16"	1
51	KHT5500-	KHT9625.1.13-	Declutch shift (Lower)	1
52	KHT5500-		Check nut 5/8"	1
53	KHT5500-	XYQ12.Z-27A	Support ring (2)	2
54	KHT5500-	GB/T308	Steel ball φ6	56
55	KHT5500-		Cylindrical roller 10×25	28
56	KHT5500-	KHT9625.1.8-1	Mandrel	1
57	KHT5500-	KHT9625.1.8-2	Duplex gear	1
58	KHT5500-	XYQ12.Z-29	Spacing ring	1
59	KHT5500-	XYQ12.Z-45	Positioning piece	1

- Assembly of safety door (Fig10, Table 7)

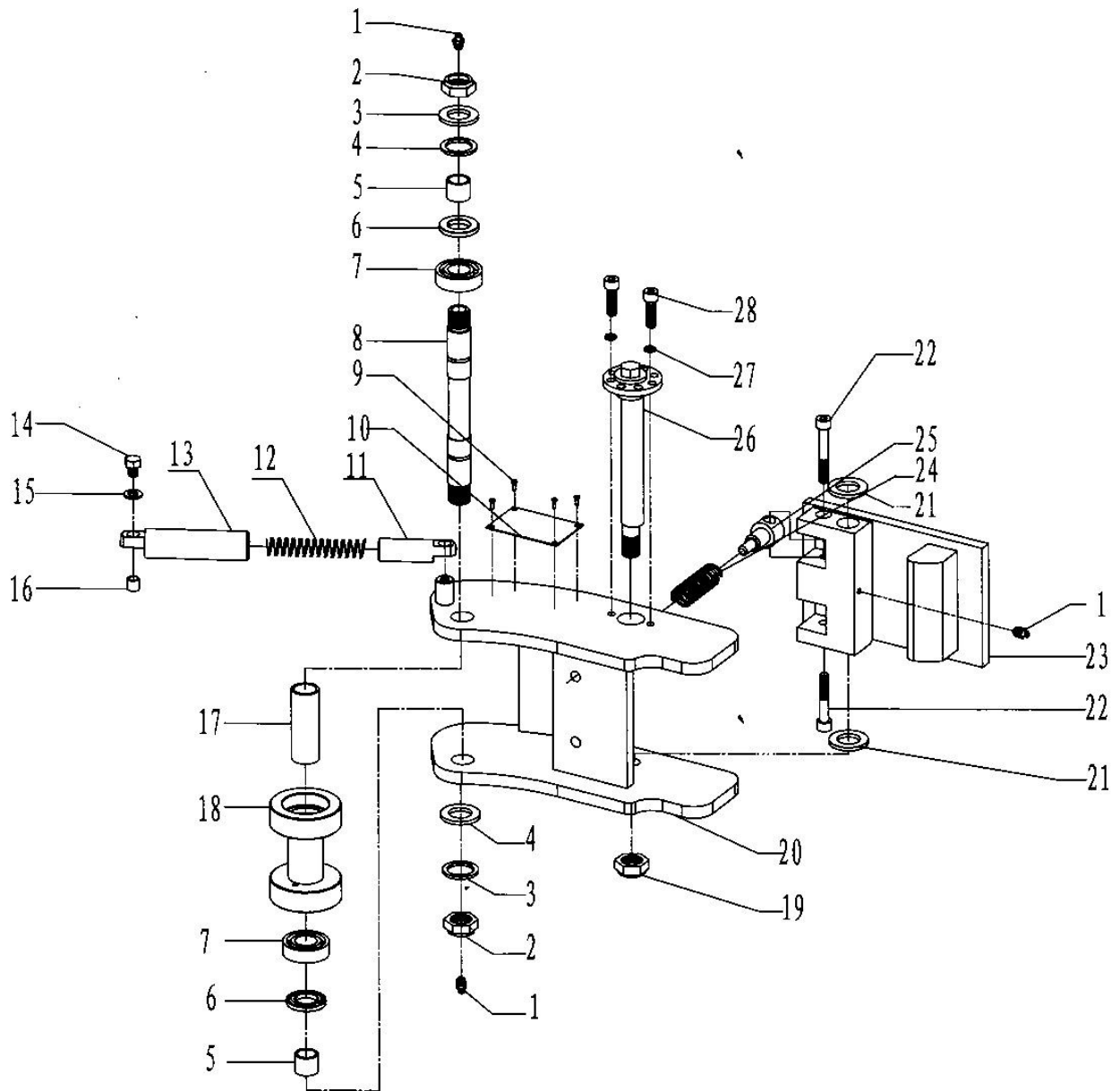

Fig. 10

Table 7 List of Safety door assembly

No.	Purchase	Drawing No.	Names and specifications of parts	Quanti
1	KHT5500-20	GB1152	Oil cup M6	3
2	KHT5500-67	KHT5500.1.9.1	Check nut 15/16"-12UN	2
3	KHT5500-68	GB/T95	Washer 24	2
4	KHT5500-158	KHT5500.1.10-	Washer	2
5	KHT5500-159	KHT5500.1.10-	Lining	2
6	KHT5500-72	KHT5500.1.9-1	Washer	2
7	KHT5500-73	GB/T276	Aligning ball shaft 1205	2
8	KHT5500-161	KHT5500.1.10-	Door spindle	1
9	KHT5500-162	GB/T872	Rivet 4×5	4
10	KHT5500-163	KJD9625.15-1	Warning plate	1
11	KHT5500-164	TQ245.13.2-3	Sleeve rod	1
12	KHT5500-165	TQ245.13.2-2	Spring	1
13	KHT5500-166	TQ245.13.2-1	Sleeve	1
14	KHT5500-167		Hexagon bolt 3/8"×1/2"	2
15	KHT5500-168	GB/T95	Washer 10	2
16	KHT5500-169	TQ245.13-1	Bushing (1)	4
17	KHT5500-74	KHT5500.1.9-2	Lining	1
18	KHT5500-75	KHT5500.1.9-3	Alignment idler wheel	1
19	KHT5500-170		Check nut 3/4-16UNF	1
20	KHT5500-171	KHT5500.1.10.2	Safety door	1
21	KHT5500-172	GB/T95	Washer 30	2
22	KHT5500-173		Hexagon socket cap head screws 3/8"×2"	2
23	KHT5500-174	KHT5500.1.10.1	Door knob	1
24	KHT5500-175	KHT5500.1.10-	Spring	2
25	KHT5500-176	KHT5500.1.10-	Spring guide rod	2
26	KHT5500-177	KHT5500.1.10-	Eccentric shaft	1
27	KHT5500-178		Spring washer 5/16"	2
28	KHT5500-179		Hexagon bolt 5/16"×1"	2

- Gear engagement assembly (**Fig11, Table8**)

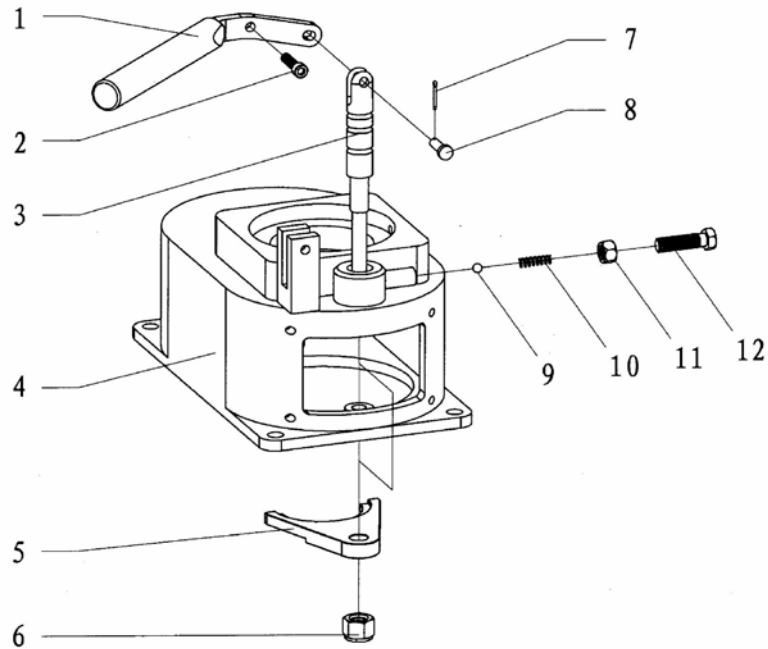

Fig. 11

Table 8 List of Gear engagement assembly

N	Purchase Code	Drawing No.	Names and specifications of parts	Quanti
1	KHT5500-180	KHT9625.1.14-	Operation rod	1
2	KHT5500-181		Hexagon socket cap head screws 5/16"×1 1/4"	1
3	KHT5500-182	KHT9625.1.14-	Declutch shift shaft (Upper)	1
4	KHT5500-97	KHT5500.1.7.1	Small cabinet	1
5	KHT5500-183	KHT9625.1.14-	Declutch shift (Upper)	1
6	KHT5500-150		Check nut 5/8"	1
7	KHT5500-143	GB91-86	Split pin 2.5×12	1
8	KHT5500-144	GB882-86	Pin Shaft B8×28	1
9	KHT5500-148		Steel ball 5/16"	1
1	KHT5500-147	TQ245.8-2	Positioning spring	1
1	KHT5500-19A		Hexagon nut 1/2"	1
1	KHT5500-146		Hexagon bolt 1/2"×1 3/4"	1

- Hydraulic pipeline (Fig 12, Table 9)

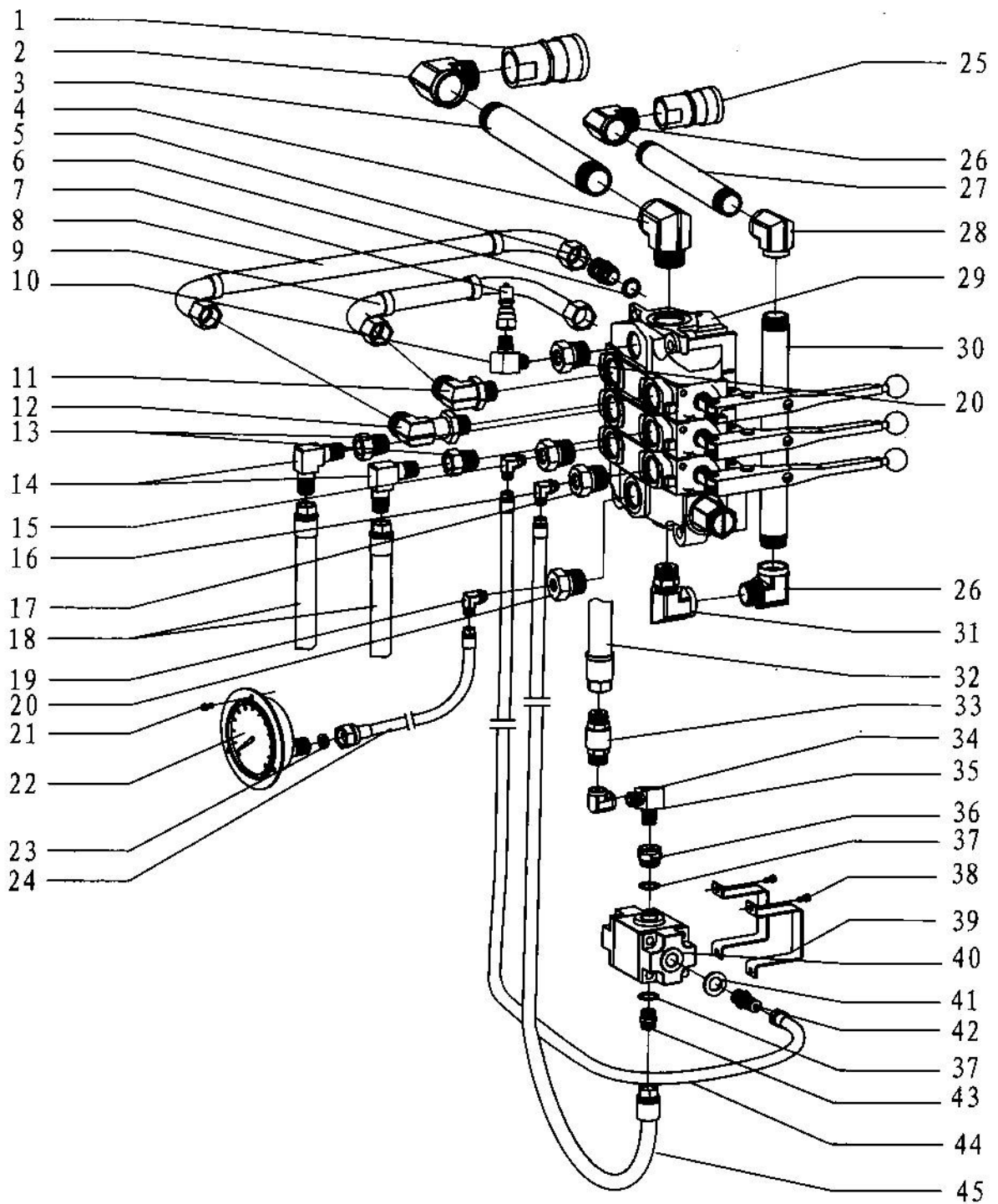

Fig. 12

Table 9 List of Hydraulic pipeline

N	Purchase	Drawing No.	Names and specifications of parts	Quantity
1	KHT5500-184	KJD9625.18.3	Quick coupling (2 1/8-12UN)	1
2	KHT5500-185	KJD9625.18-7	Bend sub (NPT1 1/4 inner and outer)	1
3	KHT5500-186	KJD9625.18-6	Tubing (NPT1 1/4)	1
4	KHT5500-187	KJD9625.18.5	Bend sub (NPT1 1/4 Inner-1 5/8-12UN Outer)	1
5	KHT5500-188	TQ508/70Y.10.8-2	Folding connector 1 5/16-12UN	2
6	KHT5500-189	GB1235-76	O-ring 35×3.1	2
7	KHT5500-190		Quick pin connector	1
8	KHT5500-	KHT5500.1.8-3	High-pressure hose 25 II -590	1
9	KHT5500-	KHT5500.1.8-2	High-pressure hose 25 II -265×160	1
1	KHT5500-193	TQ508/70Y.10.8-4	Right-angle bend sub (1 5/16-12UN Outer)	1
1	KHT5500-194	KJD9625.18.1 (3	Right-angle connector (9/16-18UNF-1/4NPT)	1
1	KHT5500-195	TQ508/70Y.10.6	Bend sub (1 5/16-12UN)	1
1	KHT5500-196	KJD9625.18-2(2)	Adapter connector (1 5/16-12UN-NPT1/2)	2
1	KHT5500-197	KJD9625.18-3	Right angle adaptor(NPT1/2)	2
1	KHT5500-198	TQ508/70Y.10.10	Small composite connector 7/16-20UNF	1
1	KHT5500-199	TQ508/70Y.10.9(2)	Combination of bent sub (3/4-16UNF)	1
1	KHT5500-200	TQ508/70Y.10-10	Adapter connector 1 5/16	2
1	KHT5500-201		Hose 10 II -1400(3/4-16UNF flared type)	2
1	KHT5500-202	KJD9625.18.1	Bend sub (9/16-18UNF)	1
2	KHT5500-203	KJD9625.18-1(2)	Reduced connector (1 5/16-12UN-9/16UNF)	2
2	KHT5500-204	GB/T820	Countersunk raised head screw M5×10	3
2	KHT5500-205		Pressure gauge Y-100ZT(0-3600PSI)	1
2	KHT5500-206		Teflon washer	1
2	KHT5500-207		Hose 6 II -850(M20×1.5-9/16UNF flared type)	1
2	KHT5500-208	KJD9625.18.4	Quick coupling (1 7/8-12UN)	1
2	KHT5500-209	KJD9625.18-8	Bend sub (NPT1 Inner and Outer)	2
2	KHT5500-210	KJD9625.18-9	Tubing (NPT1)	1
2	KHT5500-211	KJD9625.18-10	Bend sub (NPT1 Inner)	1
29	KHT5500-212	DL(1).0C	Multi-way valve assembly (quintuple valve)	1
	KHT5500-		Multi-way valve assembly(Parker)	1
3	KHT5500-213	KJD9625.18-9 (2	Tubing (NPT1)	1

N	Purchase Code	Drawing No.	Names and specifications of parts	Quantity
3	KHT5500-214	KJD9625.18.6	Bend sub (NPT1 Inner-1 5/16-12UN Outer)	1
3 2	KHT5500-215		Hose 10 II -2500 (One end: 3/4-16UNF Flared)	1
3	KHT5500-216		Quick connector M24×1.5	1
3	KHT5500-217	YG-60	Right-angle connector M24×1.5	
3	KHT5500-218	YG-61	Right-angle connector NPT1/2	
3	KHT5500-219	YG-59	Adapter connector (M22×1.5/NPT1/2)	
3	KHT5500-221	GB/T3452	O-ring 22.4×2.65	2
3 8	KHT5500-222		Hexagon socket cap head screws 1/4"-20UNC×1/2"	4
3	KHT5500-223	KHT9625.1.9-	Fixing clip	2
4	KHT5500-224	A1Y-Ha10	Hydraulic check valve	1
4	KHT5500-225		Copper gasket 20×14×2	1
4	KHT5500-226	YG-36	Adapter connector (M22×1.5-3/4UNF)	1
4	KHT5500-228	YG-57	Adapter connector (M22×1.5/ 3/4UNF)	1
4	KHT5500-227		Hose 6 II -600(7/16-20UNF Flared type, 90°)	1
4	KHT5500-220		Hose 10 II -600(7/16-20UNF Flared type, 90°)	1

- Composite valve (**Fig 13, Table 10**)

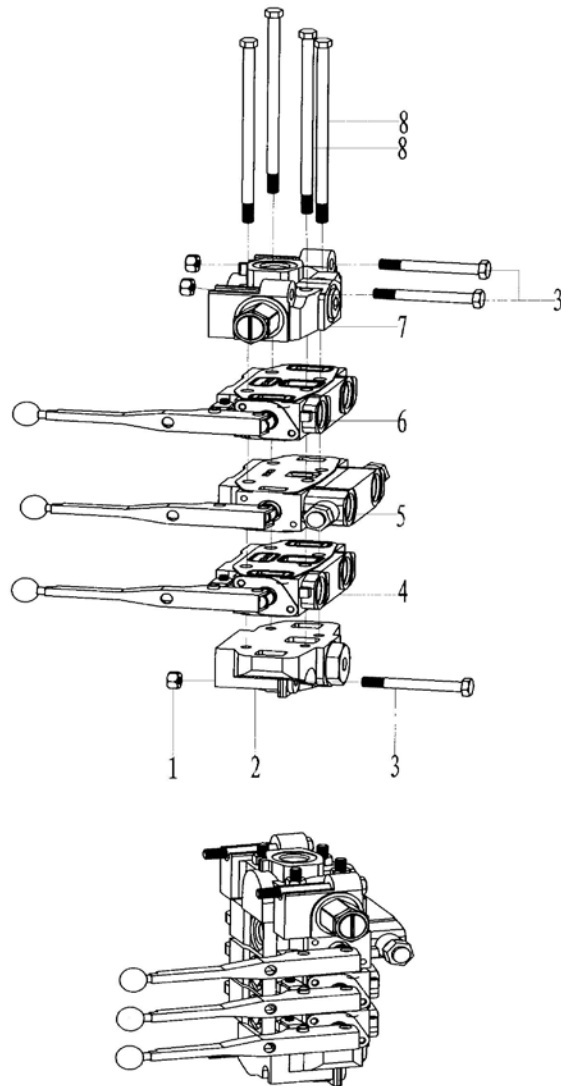

Fig. 13

Table 10 List of Composite valve

N	Purchase Code	Drawing No.	Names and specifications of parts	Quanti
1	KHT5500-19		Hexagon check nut 1/2"	3
2	KHT5500-229		Connection plate assembly	1
3	KHT5500-230		Hexagon bolt 1/2"UNC×4 1/2 "	3
4	KHT5500-231		Manual reversing valve (Y)	1
5	KHT5500-232		Manual reversing valve (O)	1
6	KHT5500-233		Manual reversing valve (Y)	1
7	KHT5500-234		Overflow valve assembly	1
8	KHT5500-235		Bolt 1/2"UNC	4

- Quick coupling (2 1/8-12UN) (Fig 14, Table 11)

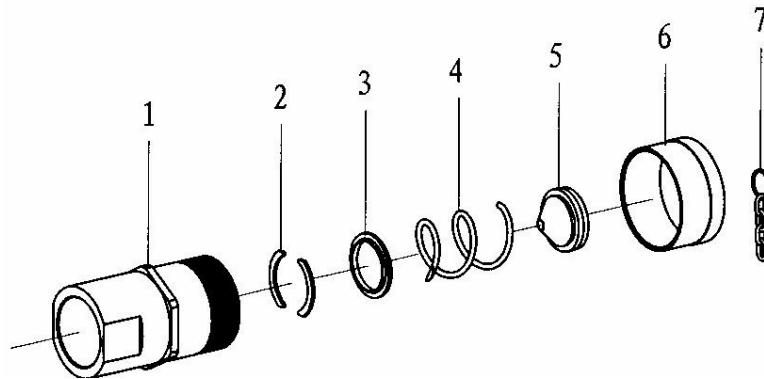

Fig. 14

Table 11 List of Quick coupling (2 1/8-12UN)

N	Purchase Code	Drawing No.	Names and specifications of	Quanti
1	KHT5500-236	KJD9625.18.3.1-2	Connector body	1
2	KHT5500-237	KJD9625.18.3.1-5	Clamping piece	2
3	KHT5500-238	KJD9625.18.3.1-4	Washer	1
4	KHT5500-239	KJD9625.18.3.1-3	Spring	1
5	KHT5500-240	KJD9625.18.3.1.1	Connector element	1
6	KHT5500-241	KJD9625.18.3.1-1	End cover	1
7	KHT5500-242	KJD9625.18.3.1.2	Composite chain	1

- Quick coupling (1 7/8-12UN) (Fig15, Table 12)

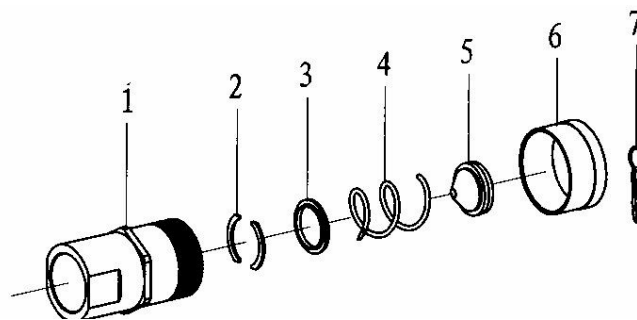

Fig. 15

Table 12 List of Quick coupling (1 7/8-12UN)

N	Purchase Code	Drawing No.	Names and specifications of	Quanti
1	KHT5500-243	KJD9625.18.4.1-2	Connector body	1
2	KHT5500-244	KJD9625.18.4.1-5	Clamping piece	2
3	KHT5500-245	KJD9625.18.4.1-4	Washer	1
4	KHT5500-246	KJD9625.18.4.1-3	Spring	1
5	KHT5500-247	KJD9625.18.4.1.1	Connector element	1
6	KHT5500-248	KJD9625.18.4.1-1	End cover	1
7	KHT5500-242	KJD9625.18..3.1.2	Composite chain	1

- Bend sub (1 5/16-12UN) (**Fig16, Table 13**)

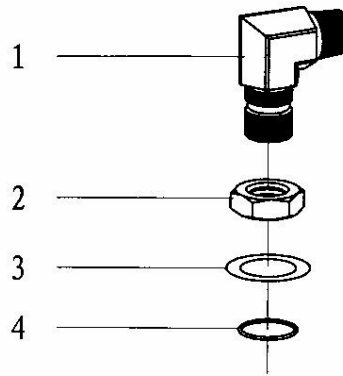

Fig.16

Table 13 List of Bend sub (1 5/16-12UN)

N	Purchase Code	Drawing No.	Names and specifications of	Quanti
1	KHT5500-250	KJD9625.18.2-1	Bend sub (1 5/16-12UN)	1
2	KHT5500-251	KJD9625.18.2-2	Hexagon nut 1 5/16	1
3	KHT5500-252		Washer $\Phi 44.5 \times \Phi 30.5 \times 1.5$	1
4	KHT5500-189	GB1235-76	O-ring 35×3.1	1

- Bend sub (9/16-18UNF) (**Fig 17, Table 14**)

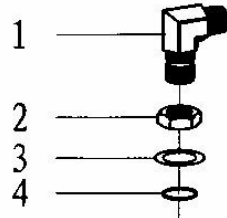

Fig. 17

Table 14 List of Bend sub (9/16-18UNF)

N	Purchase Code	Drawing No.	Names and specifications of	Quanti
1	KHT5500-254	KJD9625.18.1-1	Bend sub (9/16-18UNF)	1
2	KHT5500-255	KJD9625.18.1-2	Hexagon nut 9/16	1
3	KHT5500-256		Washer $\Phi 20.3 \times \Phi 12.7 \times 1$	1
4	KHT5500-257	GB1235-76	O-ring 16 \times 2.4	1

15. Bend sub (NPT1 1/4-1 5/8-12UN) (**Fig18, Table 15**)

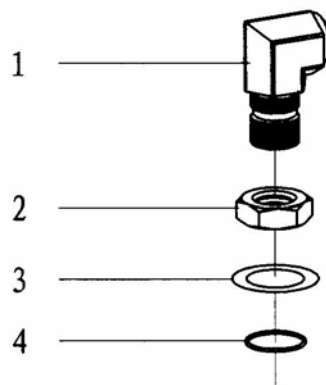

Fig. 18

Table 15 List of Bend sub (NPT1 1/4-1 5/8-12UN)

N	Purchase Code	Drawing No.	Names and specifications of parts	Quanti
1	KHT5500-258	KJD9625.18.5-1	Bend sub (NPT1 1/4-1 5/8-12UN)	1
2	KHT5500-259	KJD9625.18.5-2	Hexagon nut 1 5/8	1
3	KHT5500-260		Washer $\Phi 55 \times \Phi 38.5 \times 1.5$	1
4	KHT5500-261	GB1235-76	O-ring 45 \times 3.1	1

1. Bend sub (NPT1-1 5/16-12UN) (Fig 19, Table 16)

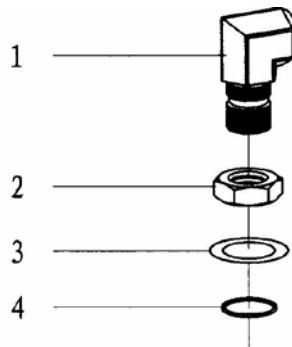

Fig. 19

Table 16 List of Bend sub (NPT1-1 5/16-12UN)

N	Purchase Code	Drawing No.	Names and specifications of parts	Quanti
1	KHT5500-262	KJD9625.18.6-1	Bend sub (NPT1-1 5/16-12UN)	1
2	KHT5500-263	KJD9625.18.6-2	Hexagon nut 1 5/16	1
3	KHT5500-252		Washer $\Phi 44.5 \times \Phi 30.5 \times 1.5$	1
4	KHT5500-189	GB1235-76	O-ring 35 \times 3.1	1

2. Assembly of suspension rod (Fig20, Table 17)

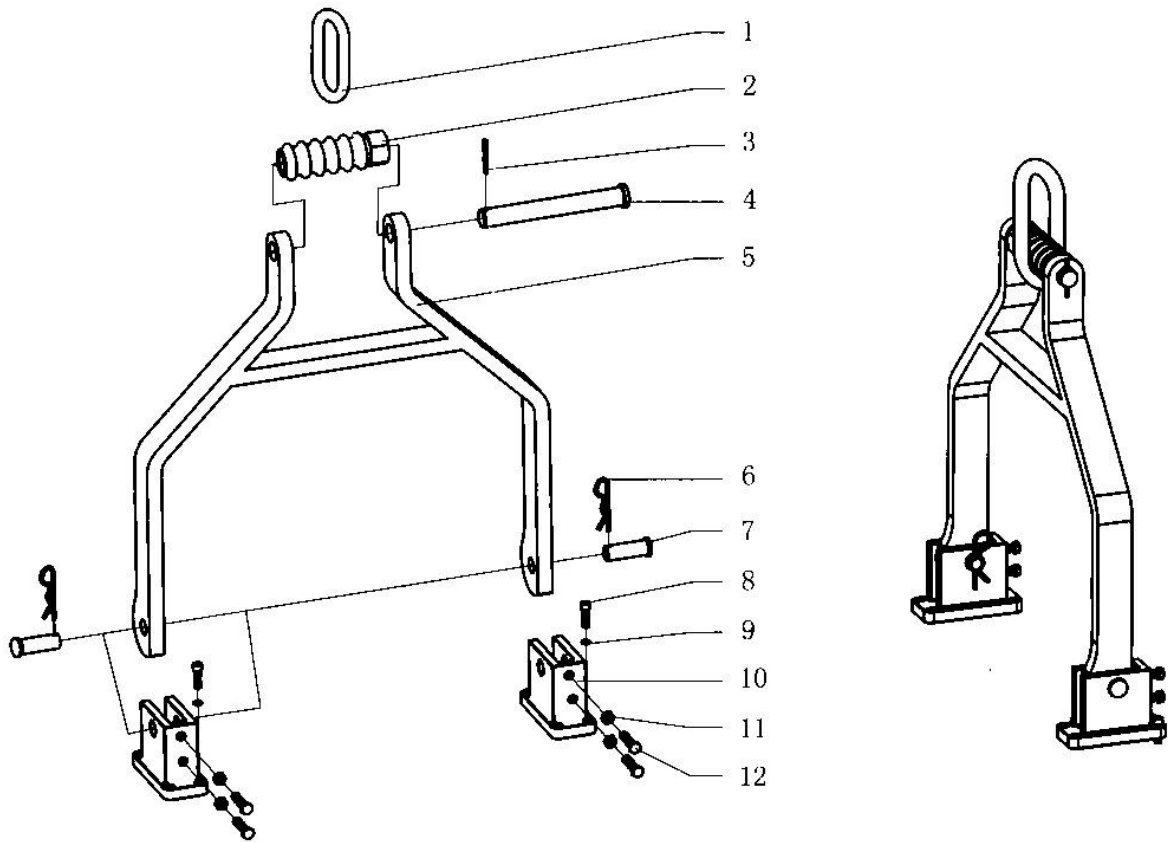

Fig. 20

Table 17 List of suspension rod assembly

N	Purchase Code	Drawing No.	Names and specifications of parts	Quanti
1	KHT5500-264		Wire rope (5T)	1
2	KHT5500-265	TQ245.15(2)-1	Screw bar	1
3	KHT5500-266	GB/T91	Split pin 6×45	1
4	KHT5500-267	TQ245.15(2)-2	Pin shaft	1
5	KHT5500-268	KHT5500.1.12.1	Suspension rod	1
6	KHT5500-269	TQ245-2	Circlip	2
7	KHT5500-270	GB/T882	Pin Shaft B25×70	2
8	KHT5500-901		Hexagon socket cap head screws 3/8"×1 1/2"	8
9	KHT5500-63		Spring washer 3/8"	8
1	KHT5500-271	KHT9625.1.16-1	Suspension support	2
1	KHT5500-272		Hexagon thin nut 1/2"	4
1	KHT5500-273		Hexagon bolt 1/2"×2"	4

3. Assembly of back tong (Fig 21, Table 18)

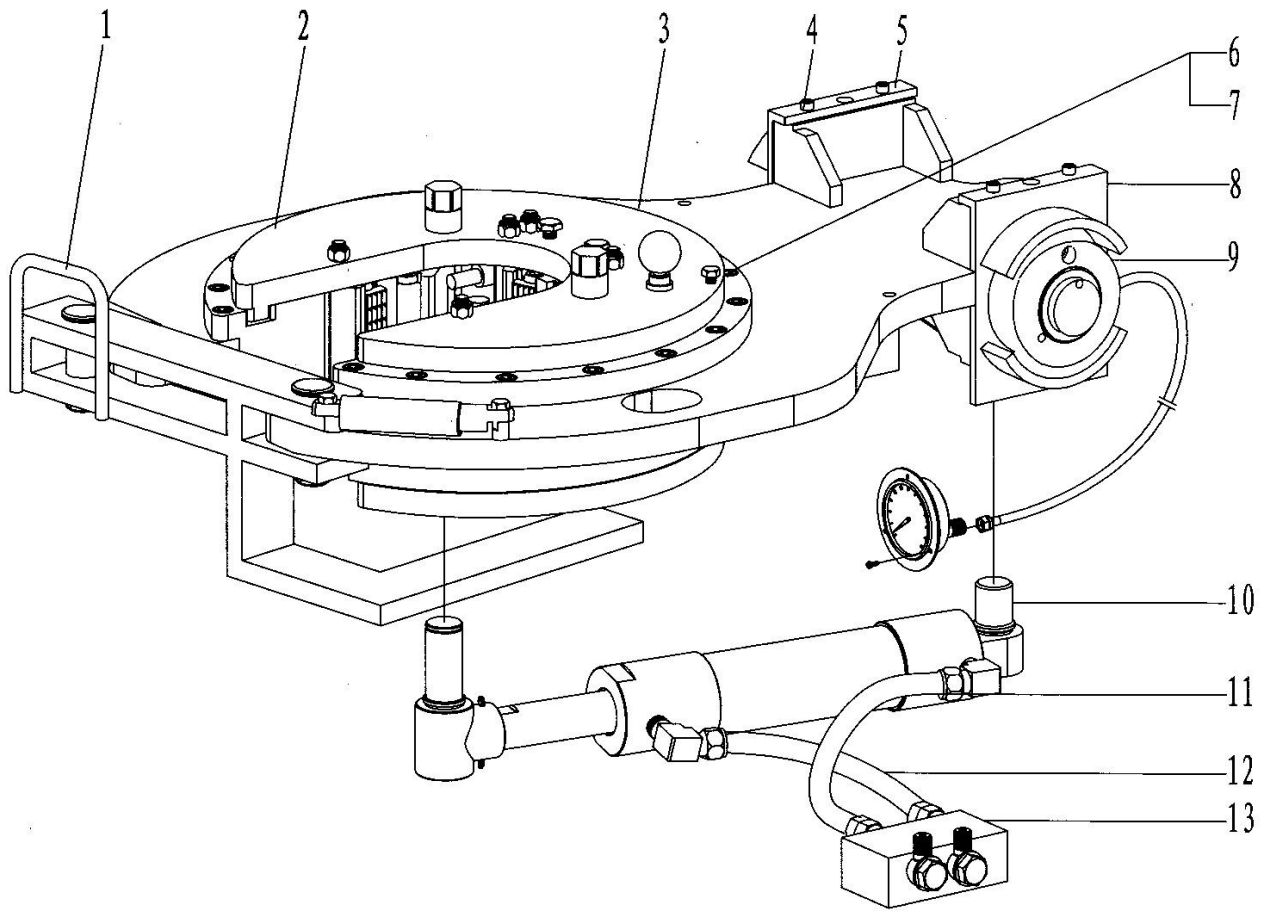

Fig. 21

Table 18 List of Back tong assembly

Ite	Purchase Code	Drawing No.	Descripti	Quanti
1	KHT5500-600	KHT5500.2 (2)	Backup Tong Safety door assembly	1
2	KHT5500-601	KHT5500.2 (2)	Backup Tong head assembly	1
3	KHT5500-602	KHT9625.2 (2)	Backup Tong	1
4	KHT5500-603		Hexagon Socket Head Screw5/16"×3/4"	4
5	KHT5500-604	KHT5500.2.9	Limit seat	1
6	KHT5500-605		Hexagon Socket Head Screw1/2"×1 1/2"	17
7	KHT5500-86		Spring washer1/2"	17
8	KHT5500-607	KHT5500.2.8	Torque cylinder connected seat	1
9	KHT5500-608		Torque testing assembly	1
10	KHT5500-609	KHT5500.2 (2)	Transmission assembly	1
11	KHT5500-610		Hose 10 II -350 (3/4-16UNF)	1
12	KHT5500-611		Hose 10 II -300(3/4-16UNF)	1
13	KHT5500-612		Hydraulic lock	1

Table 19 List of Backup Tong Transmission assembly

Ite	Purchase Code	Drawing No.	Descripti	Quanti
1	KHT5500-18	KHT5500.1.1-4	Jaw set bolt	2
2	KHT5500-19		Hexagon check nut 1/2"	12
3	KHT5500-620	KHT5500.2 (2) .1-1	Upper jaw set frame	1
4	KHT5500-281B	KHT5500.2 (2)	Rear jaw set assembly	Each1
5	KHT5500-282B	KHT5500.2 (2)	Front jaw set assembly	Each2
6	KHT5500-28	KHT5500.1.1-10	Support screw	4
7	KHT5500-623	KHT5500.2 (2) .1-2	Ramp body	1
8	KHT5500-624	KHT5500.2 (2) .1-3	Lower jaw set frame	1
9	KHT5500-625	KHT5500.2 (2) .1.3.1	Reseat	4
10	KHT5500-380	KHT5500.1.1-11B	Spring pocket	4
11	KHT5500-381	KHT5500.1.1-8B	Spring	4
12	KHT5500-382	KHT5500.1.1-13B	Leveling screw	4
13	KHT5500-629		Hexagon Socket Head	8
14	KHT5500-30B	KHT9625.1.1-8	Limiting plate	2
15	KHT5500-32(1)	KHT9625.1.1.1-2(1)	Die1 (7/16")	Each6
	KHT5500-32(2)	KHT9625.1.1.1-2(2)	Die2 (1/2")	Each6
	KHT5500-32(3)	KHT9625.1.1.1-2(3)	Die3 (9/16")	Each6
	KHT5500-32(4)	KHT9625.1.1.1-2(4)	Die4 (5/8")	Each6
	KHT5500-32(5)	KHT9625.1.1.1-2(5)	Die5 (11/16")	Each6
	KHT5500-32(6)	KHT9625.1.1.1-2(6)	Die6 (3/4")	Each6
	KHT5500-32(7)	KHT9625.1.1.1-2(7)	Die7 (13/16")	Each6
	KHT5500-32(8)	KHT9625.1.1.1-2(8)	Die8 (7/8")	Each6
	KHT5500-32(9)	KHT9625.1.1.1-2(9)	Die9 (15/16")	Each6
	KHT5500-	KHT9625.1.1.1-2(10)	Die10 (1")	Each6
	KHT5500-	KHT9625.1.1.1-2(11)	Die11 (1 1/16")	Each6

Ite	Purchase	Drawing No.	Descripti	Quanti
16	KHT5500-	KHT5500.2 (2) .2-	Front Jaw Plate 1 (6 1/2")	Each
	KHT5500-	KHT5500.2 (2) .2-	Front Jaw Plate 2 (5 1/2")	Each2
	KHT5500-	KHT5500.2 (2) .2-	Front Jaw Plate 3 (5")	Each2
	KHT5500-	KHT5500.2 (2) .2-	Front Jaw Plate 4 (4 1/2")	Each2
	KHT5500-	KHT5500.2 (2) .2-	Front Jaw Plate 5 (3 1/2")	Each
	KHT5500-	KHT5500.2 (2) .2-	Front Jaw Plate 6 (2 7/8")	Each2
	KHT5500-	KHT5500.2 (2) .2-	Front Jaw Plate 7 (2 3/8")	Each
17	KHT5500-49	KHT9625.1.1.1-4	Roller	3
18	KHT5500-50		Hexagon socket head cap screw	12
19	KHT5500-51	KHT9625.1.1.1-3	Roller shaft	3
20	KHT5500-20	GB/T1152	Oil Cup M6×1	3
21	KHT5500-	KHT5500.2 (2) .5-	Rear jaw plate1 (6 1/2")	Each
	KHT5500-	KHT5500.2 (2) .5-	Rear jaw plate2 (5 1/2")	Each
	KHT5500-	KHT5500.2 (2) .5-	Rear jaw plate3 (5")	Each
	KHT5500-	KHT5500.2 (2) .5-	Rear jaw plate4 (4 1/2")	Each1
	KHT5500-	KHT5500.2 (2) .5-	Rear jaw plate5 (3 1/2")	Each1
	KHT5500-	KHT5500.2 (2) .5-	Rear jaw plate6 (2 7/8")	Each
	KHT5500-	KHT5500.2 (2) .5-	Rear jaw plate7 (2 3/8")	Each
22	KHT5500-167		Hexagon Head Bolt3/8"×1/2"	1
23	KHT5500-59	KHT9625.1.1-10	Limiting bolt	2
24	KHT5500-632	KHT9625.2 (2) .1-4	Bolt	1
25	KHT5500-633	KJD9625.2.1-7	Combination chain	1
26	KHT5500-65	TQ340/35Y.1.5.2-05	Ball knob	1
27	KHT5500-31	KHT5500.1.1-5	Double threaded screw	4

5. Clamping cylinder assembly (Fig23, Table 20)

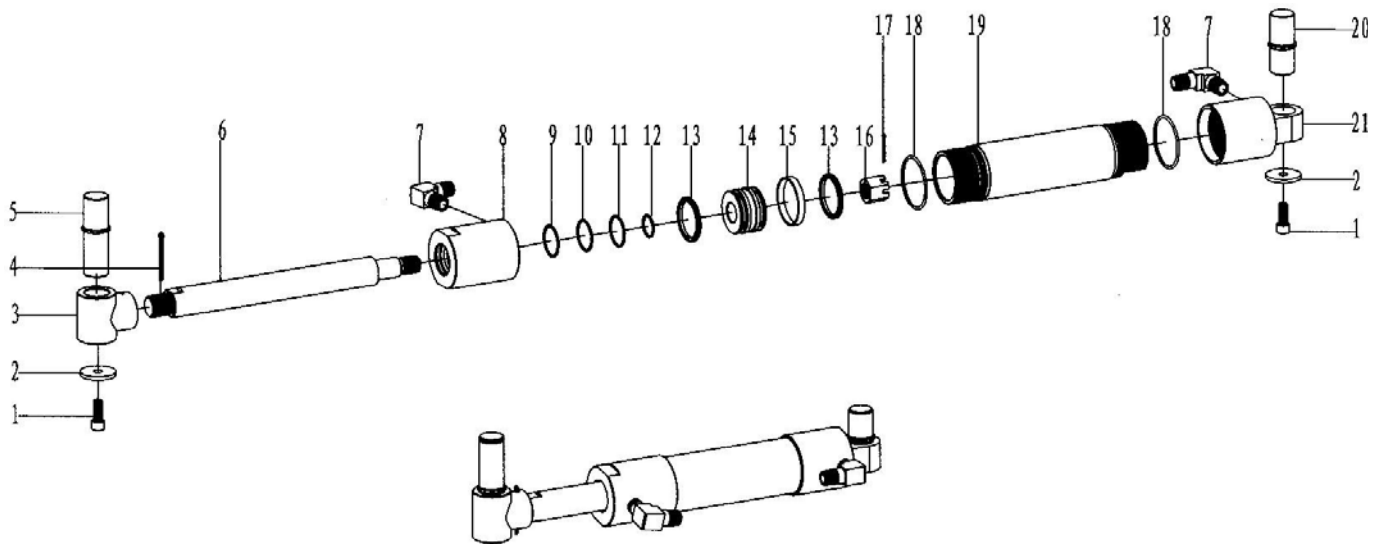

Fig. 23

Table 20 List of Clamping cylinder assembly

Ite	Purchase	Drawing No.	Descripti	Quanti
1	KHT5500-		Hexagon Head Bolt3/8"×3/4"	1
2	KHT5500-	KHT5500.2 (2)	Ring	2
3	KHT5500-	KHT9625.2 (2)	Rod adaptor	1
4	KHT5500-	GB/T91	Cotter pin5×65	1
5	KHT5500-	KHT5500.2 (2)	Pin shaft(1)	1
6	KHT5500-	KHT5500.2 (2)	Piston rod	1
7	KHT5500-	KJD9625.18-3	Right angle adaptor(NPT1/2)	1
8	KHT5500-	KHT9625.2 (2)	Cylinder end adaptor(1)	1
9	KHT5500-	GB/T10708.3	Seal FA48×40×5	1
10	KHT5500-	GB/T3452.1	Retainer ringA40.5×45.5×1.5	1
11	KHT5500-	GB/T3452.1	O-Ring41.2×3.55	1
12	KHT5500-	GB/T3452.1	O-Ring28×2.65	1
13	KHT5500-	GB/T10708.1	Y O-RingY63×53×6.3	2
14	KHT5500-	KHT9625.2 (2)	Piston	1
15	KHT5500-	GB/T15242.2	Support Ring SD 0630C- II A	1
16	KHT5500-	GB/T6178	Nut M24	1
17	KHT5500-	GB/T91	Cotter pin5×40	1
18	KHT5500-	GB/T3452.1	O-Ring69×3.55	2
19	KHT5500-	KHT5500.2 (2)	Oil Cylinder	1
20	KHT5500-	KHT5500.2 (2)	Pin shaft(2)	1
21	KHT5500-	KHT9625.2 (2)	Cylinder end adaptor(2)	1

6. Backup Tong Safety door assembly (Fig24, Table21)

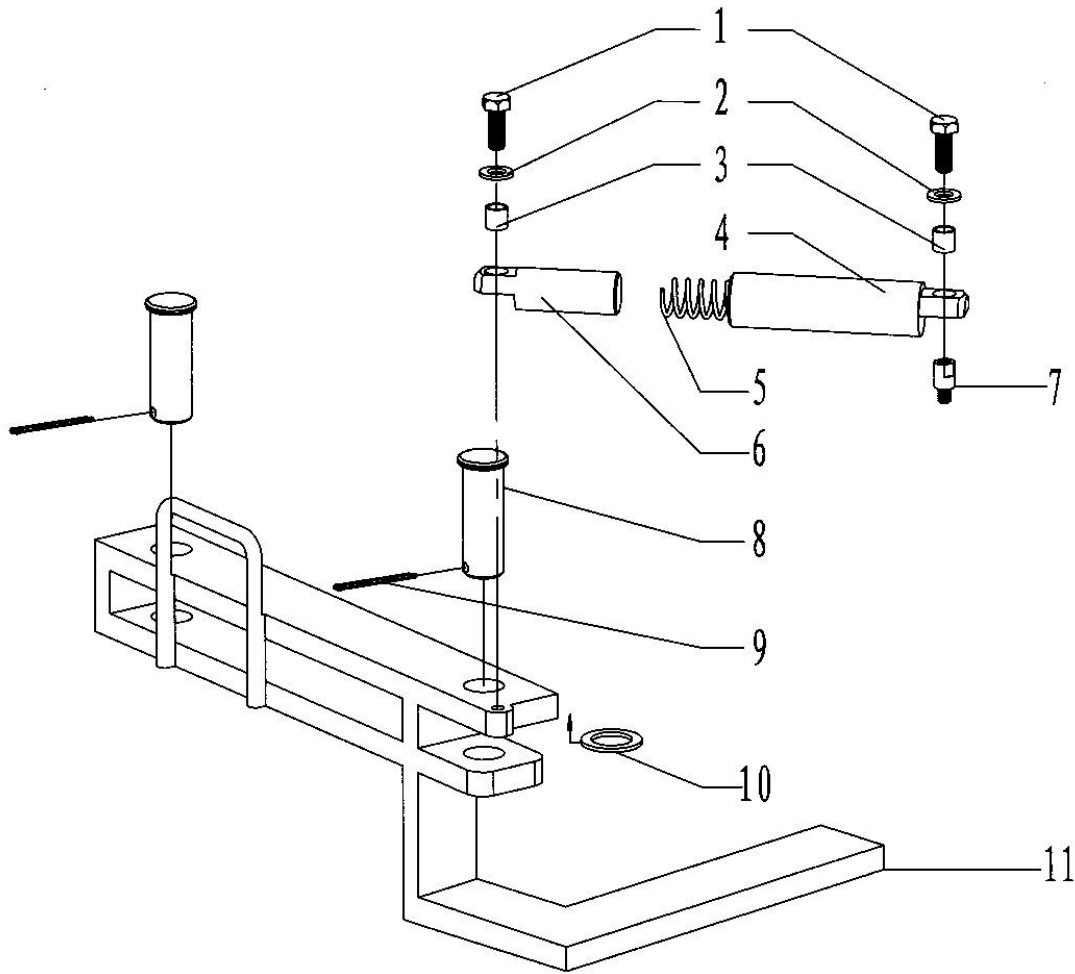

Fig. 24

Table 21 List of Backup Tong Safety door assembly

Ite	Purchase	Drawing No.	Descripti	Quanti
1	KHT5500-69		Hexagon socket cap head screws 3/8"×1	2
2	KHT5500-62	GB/T95	Flat washer10	2
3	KHT5500-	TQ245.13-1	Bushing (1)	2
4	KHT5500-	TQ245.13.2-1	Sleeve	1
5	KHT5500-	TQ245.13.2-2	Spring	1
6	KHT5500-	TQ245.13.2-3	Sleeve rod	1
7	KHT5500-	KHT9625.2 (2) .4-	support	1
8	KHT5500-	GB/T882	Pin shaft32×90	2
9	KHT5500-	GB/T91	Cotter Pin6.3×50	2
10	KHT5500-	KHT9625.2 (2) .5-	Copper Cushion	1
11	KHT5500-	KHT5500.2 (2)	Safety door	1

7. Assembly of suspension chain (Fig 25, Table 22)

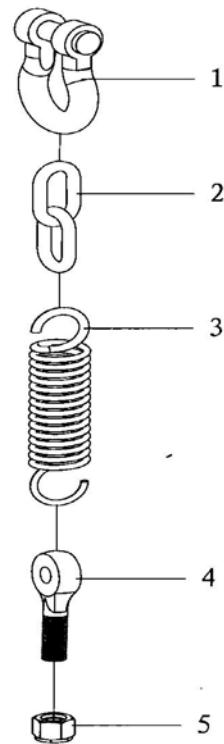

Fig. 25

Table 22 List of Suspension chain assembly

N	Purchase Code	Drawing No.	Names and specifications of	Quanti
1	KHT5500-346	JB/T8112	Shackle M-BX5 ($\phi 12$)	1
2	KHT5500-347	JB/T8108.2	Chain $\phi 8$ (L=600)	1
3	KHT5500-348	KHT9625.3-1	Extension spring	1
4	KHT5500-349	KHT5500.3-2	Eyebolt	1
5	KHT5500-19		Hexagon check nut 1/2"	1

8. Assembly of front guide rod (Fig26, Table 23)

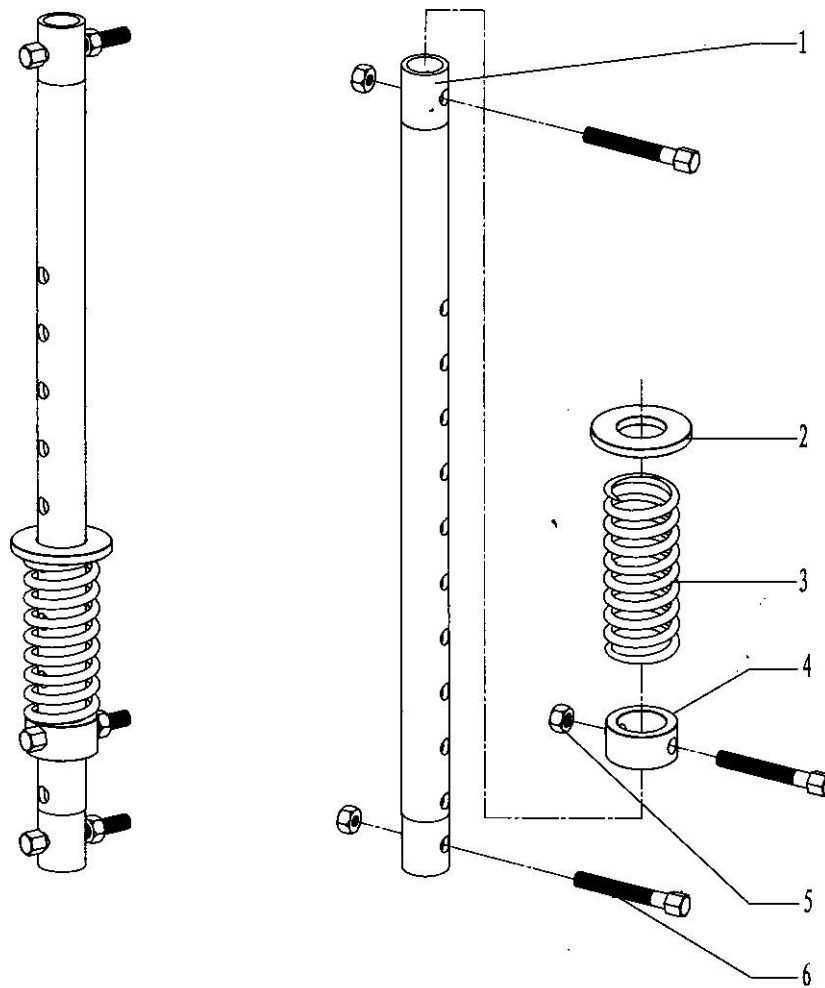

Fig. 26

Table 23 List of Front guide rod assembly

N	Purchase Code	Drawing No.	Names and specifications of	Quanti
1	KHT5500-350	KHT5500.5-1	Front guide rod	2
2	KHT5500-351	KHT5500.5-2	Washer	2
3	KHT5500-352	KHT5500.5-3	Front guide rod spring	2
4	KHT5500-353	KHT5500.5-4	Fixation sleeve	2
5	KHT5500-354		Hexagon bolt 1/2"×3 1/2"	6
6	KHT5500-19		Hexagon check nut 1/2"	6

9. Hydraulic spring tube assembly (Fig 27, Table 24)

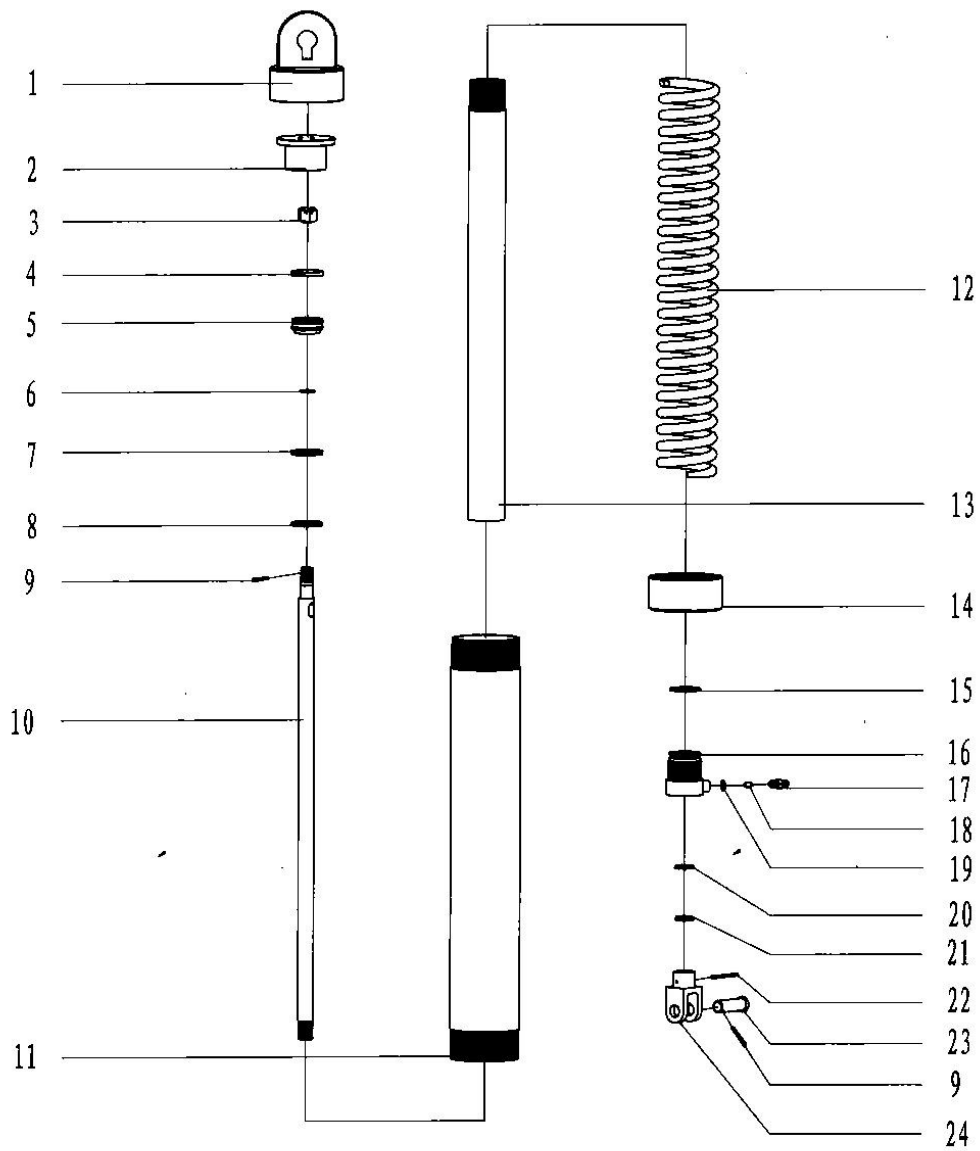

Fig. 27

Table 24 List of Hydraulic spring tube assembly

N	Purchase Code	Drawing No.	Names and specifications of parts	Quanti
1	KHT5500-355	KHT9625.1.17.2	Casket end connector	1
2	KHT5500-356	KHT9625.1.17-8	Cylinder end connector 2	1
3	KHT5500-357	GB/T6178	Slotted nut M30	1
4	KHT5500-358	GB/T15242.2	SD0800C- II A	1
5	KHT5500-359	KHT9625.1.17-7	Piston	1
6	KHT5500-360	GB/T3452.1	O-ring 32.5×3.55	1
7	KHT5500-361	GB/T10708.1	Y-ring Y80×65×9.5	1
8	KHT5500-362	KHT9625.1.17-6	Retainer ring	1
9	KHT5500-363	GB/T91	Cotter Pin6.3×50	2
1	KHT5500-364	KHT9625.1.17-5	Piston rod	1
1 1	KHT5500-365	KHT9625.1.17-3	Shell	1
	KHT5500-	KHT9625.1.17-3(2)	Shell	1
1 2	KHT5500-367	KHT9625.1.17-2	Spring	1
	KHT5500-	KHT9625.1.17-2(2)	Spring	1
1	KHT5500-366	KHT9625.1.17-4	Cylinder	1
1	KHT5500-368	KHT9625.1.17-1	End cover	1
1	KHT5500-369	GB/T3452.1	O-ring 69×5.3	1
1	KHT5500-370	KHT9625.1.17.1	Cylinder end connector 1	1
1	KHT5500-371	YG-54	Adapter connector (M18×1.5-3/4UNF)	1
1	KHT5500-372	XYQ12.YD-01.3	Choking valve element	1
1	KHT5500-288	GB/1235	O-ring 24×2.4	1
2	KHT5500-374	GB/T10708.1	Y-ring Y40×50×6.3	1
2	KHT5500-375	GB/T10708.1	Anti-dust ring FA40×48×5	1
2	KHT5500-376	GB/T91	Split pin 6.3×80	1
2	KHT5500-377	GB/T882	Pin Shaft 32×90	1
2	KHT5500-378	TQ340/35YA.1.16-1	Suspension head	1

10. Torque testing assembly (Fig28, Table25)

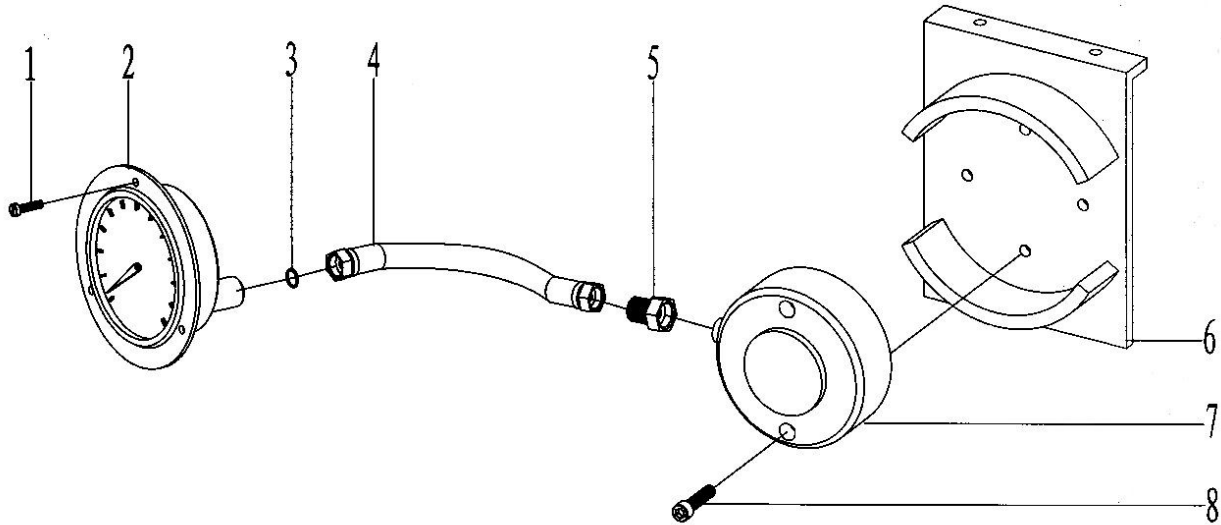

Fig .28

Table 25 List of Torque testing assembly

Ite	Purchase	Drawing No.	Names and specifications of parts	Quanti
1	KHT5500-	GB/T820	Countersunk raised head screw M5×10	3
2	KHT5500-		Torque gaugeYN100ZT(0-25000ft.lb)	1
3	KHT5500-		Teflon washer	1
4	KHT5500-		Hose 6 II -1500	1
5	KHT5500-	YG-52	Adapter connector (M20-NPT1/4)	1
6	KHT5500-	KHT5500.2.8	Torque cylinder connected seat	1
7	KHT5500-		Pressure cylinder	1
8	KHT5500-		Hexagon Socket Head Screw5/16"×2 "	2

11. Torque testing system of master tong (Fig29, Table26)

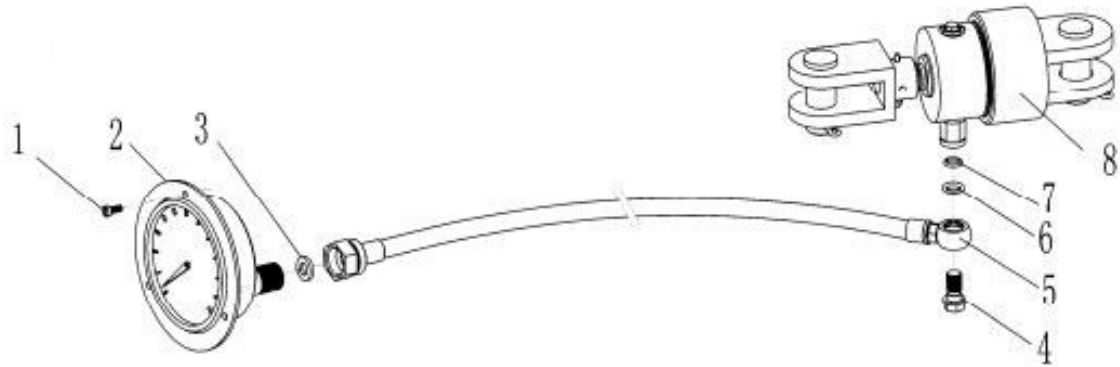

Fig .29

Table 26 List of Torque testing system of master tong

Item	Purchase Code	Drawing No.	Names and specifications of parts	Quantity
1	KHT5500-204	GB/T65	Countersunk raised head screw M5×10	3
2	KHT5500-842		Torque gauge YN100ZT(0-25000ft.lb)	1
3	KHT5500-206		Teflon washer	1
4	KHT5500-860	XYQ12.Z-40.02	Oil Passing Bolt	1
5	KHT5500-861	JB/ZQ4427	Hose adapter 6 I -750	1
6	KHT5500-862		Shim (Φ20×Φ14×3)	1
7	KHT5500-863	GB1235	O Ring 18×2.4	1
8	KHT5500-864	KD13375.1.12.1	Tension cylinder	1

12. Oil filled equipment (Fig30, Table27)

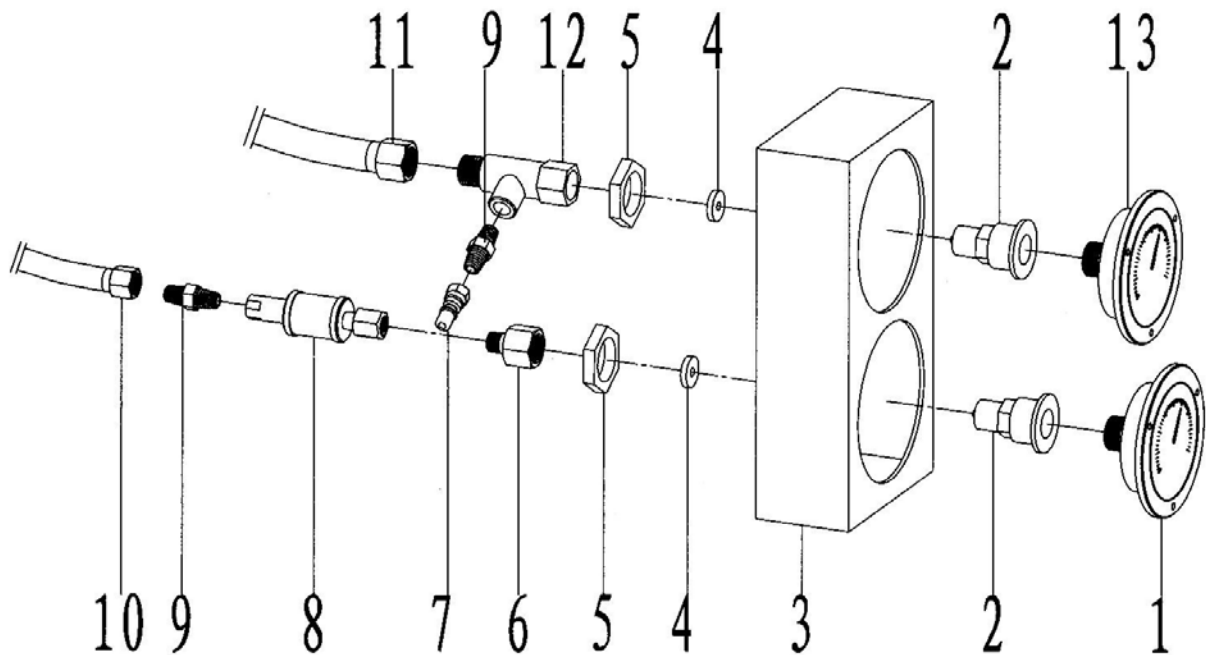

Fig.30

Table27 List of Oil filled equipment

Ite	Purchase Code	Drawing No.	Names and specifications of parts	Quanti
1	KHT5500-842		Torque gaugeYN100ZT(0-25000ft.lb)	1
2	KHT5500-880	KJD9625.11 (2) -1	Attchment connector	2
3	KHT5500-93	KJD9625.11 (2)	Pressure gauge seat	1
4	KHT5500-206		Teflon washer	2
5	KHT5500-881	KJD9625.11 (2) -2	And the nut	2
6	KHT5500-844	YG-52	Adapter connector (M20-NPT1/4)	1
7	KHT5500-190		Quick pin connector	1
8	KHT5500-882		Quick connector	1
9	KHT5500-883	YG-68	Adaptor NPT1/4"	2
10	KHT5500-843		Hose 6 II -1500	1
11	KHT5500-207		Hose 6 II -850(M20×1.5-9/16UNF Flared type)	1
12	KHT5500-884	KHT5500.1.8.1-1	Oil filled tee joint	1
13	KHT5500-205		Pressure gauge Y-100ZT(0-3600PSI)	1

13. Soft shaft door control device (Fig31, Table28)

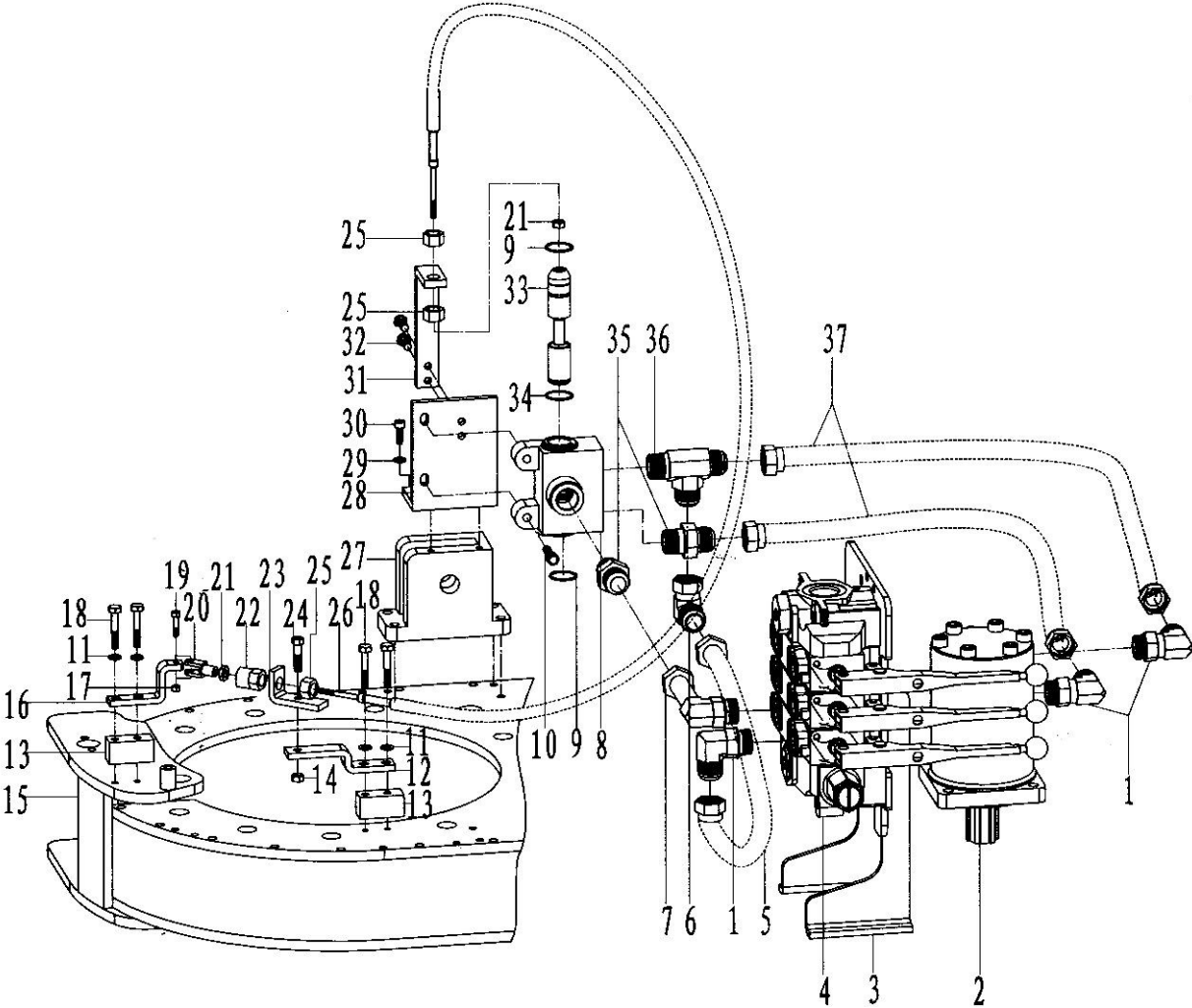

Fig.31

Table28 List of Soft shaft door control device

Ite	Purchase Code	Drawing No.	Names and specifications of parts	Quanti
1	KHT5500-824	TQ508/70Y.10.8.3	Bend adaptor (1 5/16"-12UNC)	3
2	KHT5500-87		6K-625 orbit hydraulic motor (tubular connection)	1
3	KHT5500-90A	KHT5500.1.18.1 (2	Valve connection assembly	1
4	KHT5500-212B	VG35-3-004	Multi-way valve assembly (Parker)	1
5	KHT5500-902	KHT5500.1.15D-1	Curved Hose (1 5/16-12UNC, 290×80)	1
6	KHT5500-900	TQ508/70Y.10.8.4	Bend adaptor (1 5/16"-12UNC)	1
7	KHT5500-903	KJD9625.18.2(2)	Bend adaptor (1 5/16-12UNC)	1
8	KHT5500-904	RHF-1	Valve body	1
9	KHT5500-905	GB/T89.4.1	Washer 30	2
10	KHT5500-906		Hexagon bolt 3/8-16UNC×2 1/2	2
11	KHT5500-907		Spring washer 5/16"	4
12	KHT5500-908	KHT5500.1.15C.1-5	Connection plate (2)	1
13	KHT5500-909	KHT5500.1.15C.1-1	Plate	2
14	KHT5500-910		Nut 3/8"-16UNC	3
15	KHT5500-171	KHT5500.1.10.2	Safety door	1
16	KHT5500-911	KHT5500.1.15C.1-2	Connection plate (1)	1
17	KHT5500-912		Nut 1/4"-20UNC	1
18	KHT5500-913		Hexagon bolt 5/16"-18UNC×2"	4
19	KHT5500-914		Hexagon bolt 1/4"-20UNC×1 1/2"	1
20	KHT5500-915	KHT5500.1.15C.1-3	Rotary adaptor	1
21	KHT5500-916		Nut 1/4"-28UNC	2
22	KHT5500-917	XQ4.5.Z.6-6	Protective sleeve	1
23	KHT5500-918	KHT5500.1.15C.1-4	Rotary plate	1
24	KHT5500-919		Hexagon bolt 3/8"-16UNC×3/4"	1
25	KHT5500-920		Nut 5/8"-18UNF	3
26	KHT5500-921	173-LTT-1-71	Flexible shaft	1
27	KHT5500-271B	KHT9625.1.16-1B	Suspension support	2
28	KHT5500-923	KHT5500.1.15D.1-1	Valve fixing plate (2)	1
29	KHT5500-924	KHT5500.1.15C.1-10	Washer	2
30	KHT5500-925	GB/T70	Hexagon Socket Head Screw M8×25-8.8	2
31	KHT5500-926	KHT5500.1.15C.1-6	Valve fixing plate (1)	1
32	KHT5500-927		Hexagon bolt 3/8"-16UNC×2 1/2"	2
33	KHT5500-928	RHF-2	Valve core	1
34	KHT5500-929	GB/T3452.1	O-ring 25×2.65	1
35	KHT5500-930	KHT5500.1.15C.1-9	Adaptor1 5/16-12UN-NPT1	2
36	KHT5500-931	KHT5500.1.15C.1-8	Three-way adaptor (NPT1-1 5/16-12UN)	1
37	KHT5500-932	KHT13625.1.8-1	High-pressure hose 25 II -580 (1 5/16-)	2

14. Spring lift bucket assembly (Fig32, Table29)

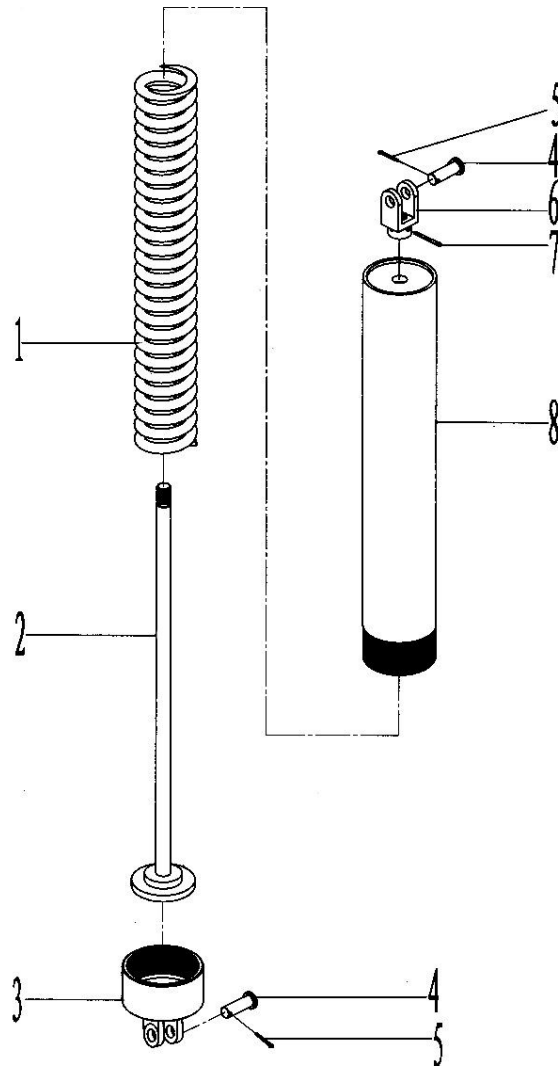

Fig.32

Table29 List of Spring lift bucket assembly

Ite	Purchase Code	Drawing No.	Names and specifications of	Quanti
1	KHT5500-890	TQ340/35Y.1.13-01	Spring	1
2	KHT5500-891	TQ340/35Y.1.13.1	Hanger rod	1
3	KHT5500-892	TQ245/20Y.1.14(2)-	End cover	1
4	KHT5500-893	GB882	Pin shaft20×60	2
5	KHT5500-894	GB91	Cotter pin4×40	2
6	KHT5500-895	XYQ12.YD-01.1	Suspended head	1
7	KHT5500-896	GB91	Cotter pin5×50	1
8	KHT5500-897	TQ340/35Y.1.13(2).	Lift bucket	1

Chapter VIII Optional Accessories

- High-pressure hose
- Quick coupling
- Model YD160-1/2 hydraulic power station
- Hydraulic casket (Fig 27, Table 24)
- Torque testing assembly (Fig28, Table25)
- Torque testing system of master tong (Fig29, Table26)
- Soft shaft door control device (Fig31, Table28)
- Spring lift bucket assembly (Fig32, Table29)
- Jaw plate assembly selection chart

Purchase Code	Drawing No.	Description	Quanti	Note
KHT5500-24 (1)	KHT5500.1.1.2 (1)	Rear jaw plate assembly(5 1/2)	1	√
KHT5500-24 (2)	KHT5500.1.1.2 (2)	Rear jaw plate assembly(5)	1	
KHT5500-24 (3)	KHT5500.1.1.2 (3)	Rear jaw plate assembly(4 1/2)	1	
KHT5500-24 (4)	KHT5500.1.1.2 (4)	Rear jaw plate assembly(3 1/2)	1	
KHT5500-24 (5)	KHT5500.1.1.2 (5)	Rear jaw plate assembly(2 7/8)	1	
KHT5500-24 (6)	KHT5500.1.1.2 (6)	Rear jaw plate assembly(2 3/8)	1	
KHT5500-26 (1)	KHT5500.1.1.1 (1)	Front jaw plate assembly(5 1/2)	each	√
KHT5500-26 (2)	KHT5500.1.1.1 (2)	Front jaw plate assembly(5)	each	
KHT5500-26 (3)	KHT5500.1.1.1 (3)	Front jaw plate assembly(4 1/2)	each	
KHT5500-26 (4)	KHT5500.1.1.1 (4)	Front jaw plate assembly(3 1/2)	each	
KHT5500-26 (5)	KHT5500.1.1.1 (5)	Front jaw plate assembly(27/8)	each	
KHT5500-26 (6)	KHT5500.1.1.1 (6)	Front jaw plate assembly(2 3/8)	each	
KHT5500-32 (1)	KHT9625.1.1.1-2 (1)	Die 1 (7/16")		
KHT5500-32 (2)	KHT9625.1.1.1-2 (2)	Die 2 (1/2")		√
KHT5500-32 (3)	KHT9625.1.1.1-2 (3)	Die 3 (9/16")		
KHT5500-32 (4)	KHT9625.1.1.1-2 (4)	Die 4 (5/8")		
KHT5500-32 (5)	KHT9625.1.1.1-2 (5)	Die 5 (11/16")		
KHT5500-32 (6)	KHT9625.1.1.1-2 (6)	Die 6 (3/4")		
KHT5500-32 (7)	KHT9625.1.1.1-2 (7)	Die 7 (13/16")		
KHT5500-32 (8)	KHT9625.1.1.1-2 (8)	Die 8 (7/8")		
KHT5500-32 (9)	KHT9625.1.1.1-2 (9)	Die 9 (15/16")		
KHT5500-32 (10)	KHT9625.1.1.1-2 (10)	Die 10 (1")		
KHT5500-32 (11)	KHT9625.1.1.1-2 (11)	Die11 (1 1/16")		
KHT5500-281 (1)	KHT5500.2 (2) .1.2 (1)	Rear jaw plate assembly (6 1/2)	1	√
KHT5500-281 (2)	KHT5500.2 (2) .1.2 (2)	Rear jaw plate assembly (5 1/2)	1	
KHT5500-281 (3)	KHT5500.2 (2) .1.2 (3)	Rear jaw plate assembly (5)	1	
KHT5500-281 (4)	KHT5500.2 (2) .1.2 (4)	Rear jaw plate assembly (4 1/2)	1	

KHT5500-281 (5)	KHT5500.2 (2) .1.2 (5)	Rear jaw plate assembly (3 1/2)	1	
KHT5500-281 (6)	KHT5500.2 (2) .1.2 (6)	Rear jaw plate assembly (2 7/8)	1	
KHT5500-281 (7)	KHT5500.2 (2) .1.2 (7)	Rear jaw plate assembly (2 3/8)	1	
KHT5500-282 (1)	KHT5500.2 (2) .1.1 (1)	Front jaw plate assembly (6)	1	√
KHT5500-282 (2)	KHT5500.2 (2) .1.1 (2)	Front jaw plate assembly (5)	1	
KHT5500-282 (3)	KHT5500.2 (2) .1.1 (3)	Front jaw plate assembly (5)	1	
KHT5500-282 (4)	KHT5500.2 (2) .1.1 (4)	Front jaw plate assembly (4)	1	
KHT5500-282 (5)	KHT5500.2 (2) .1.1 (5)	Front jaw plate assembly (3)	1	
KHT5500-282 (6)	KHT5500.2 (2) .1.1 (6)	Front jaw plate assembly (2)	1	
KHT5500-282 (7)	KHT5500.2 (2) .1.1 (7)	Front jaw plate assembly (2)	1	

Note: This kind of common jaws that we supply: (Purchase Code: KHT5500-24 (1)、KHT5500-26 (1)、KHT5500-281 (1) B、KHT5500-282 (1) B), Apply to 5 1/2 Casing.

JAW AND DIE SELECTION CHART

JAW/DIE SELECTION CHART		
JAW SIZE	3.88 (98.4mm) × 1.25 (31.8mm) × THICKNESS	BITING DIAMETER +0.06 (1.5mm)
5.5 (139.7)	0.44 (11.1)	5.63 (142.9)
	0.50 (12.7)	5.50 (139.7)
	0.56 (14.3)	5.38 (136.5)
	0.63 (15.9)	5.25 (133.4)
	0.69 (17.5)	5.13 (130.2)
	0.75 (19.1)	5.00 (127.0)
	0.81 (20.6)	4.88 (123.8)
	0.88 (22.2)	4.75 (120.7)
	0.94 (23.8)	4.63 (117.5)
	1.00 (25.4)	4.50 (114.3)
4.5 (114.3)	1.06 (27.0)	4.38 (111.1)
	0.44 (11.1)	4.63 (117.5)
	0.50 (12.7)	4.50 (114.3)
	0.56 (14.3)	4.38 (111.1)
	0.63 (15.9)	4.25 (108.0)
	0.69 (17.5)	4.13 (104.8)
	0.75 (19.1)	4.00 (101.6)
	0.81 (20.6)	3.88 (98.4)
	0.88 (22.2)	3.75 (95.3)
	0.94 (23.8)	3.63 (92.1)
1.00 (25.4)	3.50 (88.9)	
1.06 (27.0)	3.38 (85.7)	

3.5 (88.9)	0.44 (11.1)	3.63 (92.1)
	0.50 (12.7)	3.50 (88.9)
	0.56 (14.3)	3.38 (85.7)
	0.63 (15.9)	3.25 (82.6)
	0.69 (17.5)	3.13 (79.4)
	0.75 (19.1)	3.00 (76.2)
	0.81 (20.6)	2.88 (73.0)
	0.88 (22.2)	2.75 (69.9)
	0.94 (23.8)	2.63 (66.7)
	1.00 (25.4)	2.50 (63.5)
	1.06 (27.0)	2.38 (60.3)
2.875 (73)	0.44 (11.1)	3.00 (76.2)
	0.50 (12.7)	2.88 (73.0)
	0.56 (14.3)	2.75 (69.9)
	0.63 (15.9)	2.63 (66.7)
	0.69 (17.5)	2.50 (63.5)
	0.75 (19.1)	2.38 (60.3)
2.375 (60.3)	0.44 (11.1)	2.50 (63.5)
	0.50 (12.7)	2.38 (60.3)

Note: The allocated thickness of standard dies is 0.50"/12.7mm, when installed on the jaw, it can fit for the standard pipe diameter; If non-standard diameter is to be fitted, dies of different thickness can be selected according to the above table to fit for different pipe diameter; and dedicated jaw plate can be customized for non-standard pipe diameter according to actual needs.

Chapter IX Wearing Parts

No.	Purchase Code	Drawing No. or Standard No.	Names of parts	Recommended spare part quantity for one year
1	KHT5500-18	KHT5500.1.1-4	Jaw plate bolt	2
2	KHT5500-25	KHT5500.1.1.3.1	Alignment Roller	28
3	KHT5500-32	KHT9625.1.1.1-2 (1)	Die 1 (1/2")	200
4	KHT5500-49	KHT9625.1.1.1-4	Roller	10
5	KHT5500-51	KHT9625.1.1.1-3	Roller shaft	10
6	KHT5500-60	TQ340/35Y.1.5.2-02	Pin	1
7	KHT5500-66	KHT5500.1.11.1	Braking staple	4
8	KHT5500-71	KHT5500.1.9-4	Alignment shaft	9
9	KHT5500-75	KHT5500.1.9-3	Alignment Idler wheel	9
10	KHT5500-80	KHT5500.1.11-1	Double threaded screw	1
11	KHT5500-131	GB/T309	Rolling needle $\phi 5 \times 29.8$	41
12	KHT5500-153		Cylindrical roller 10 \times 25	28
13	KHT5500-358	GB/T15242.2	SD0800C- II A	1
14	KHT5500-360	GB/T3452.1	O-ring 32.5 \times 3.55	1
15	KHT5500-361	GB/T10708.1	Y-ring Y80 \times 65 \times 9.5	1
16	KHT5500-369	GB/T3452.1	O-ring 69 \times 5.3	1
17	KHT5500-288	GB/1235	O-ring 24 \times 2.4	1
18	KHT5500-374	GB/T10708.1	Y-ring Y40 \times 50 \times 6.3	1
19	KHT5500-375	GB/T10708.1	Anti-dust ring FA40 \times 48 \times 5	1
20	KHT5500-658	GB/T10708.3	Seal FA48 \times 40 \times 5	1
21	KHT5500-659	GB/T3452.1	Retainer ring A40.5 \times 45.5 \times 1.5	1
22	KHT5500-660	GB/T3452.1	O-Ring 41.2 \times 3.55	1
23	KHT5500-661	GB/T3452.1	O-Ring 28 \times 2.65	1
24	KHT5500-662	GB/T10708.1	Y O-Ring Y63 \times 53 \times 6.3	2
25	KHT5500-664	GB/T15242.2	Support Ring SD 0630C- II	1
26	KHT5500-667	GB/T3452.1	O-Ring 69 \times 3.55	2